

Low Cost Automation

MAGAZINE

Do more with less
Affordable automation
solutions with
motion plastics®



igus®.eu...
plastics for longer life® igus.eu/LCA



Automation doesn't just affect large companies. Low Cost Automation provides access for companies of all sizes.

What does igus® Low Cost Automation stand for? What options are there? How can I automate easily?

Industrial robots come at a price. Robot systems pay for themselves in three to four years. But small and medium-sized companies that want to manufacture more product variants in small batches have completely different requirements. They often find it complex and time-consuming to get into the world of automation. This magazine is intended to convince you otherwise and show that **Low Cost Automation** is a great way to increase productivity and, in addition to proven rapid amortisation, to reduce costs permanently. We, the igus® Low Cost Automation team, have set ourselves the goal of making cost-effective, user-friendly automation solutions accessible to everyone.

Sincerely,

Alexander Mühlens

Head of the Robotics Automation Technology Business Unit

Phone: +49 2203 9649-8255



The seventh axis allows flexible expansion of working space for various robots.

Build or buy your own robot

Getting into the world of automation is often considered too complex and time-consuming.

In times when robotics requirements are constantly changing, flexible modular components are indispensable. The modular system enables users to quickly create an automation solution. To make it as easy as possible for you to get started with automation, we offer expert advice and a test of your application ideas in our customer testing area at igus®. Our motto is "Test before you invest!" Depending on the scope of the application, entire processes or even just parts of processes can be automated. "Build or buy" helps you implement an automation solution that fully meets your needs. Simply choose between ready-made robotics solutions or sub-components for your individual application.



Industrial robots from
€30,000 – €250,000



Lightweight robots from
€5,000 – €30,000



igus® Low Cost Automation
from €1,000 – €5,000

Building your own robot

- Online configuration of individual robot systems
- User-friendly robot programming with the free igus® Robot Control (IRC)
- Standard components from stock, available in as little as 24 hours
- New: drygear® modular gearbox system for even more flexibility in building your automation solution. Suitable for robots or cobots

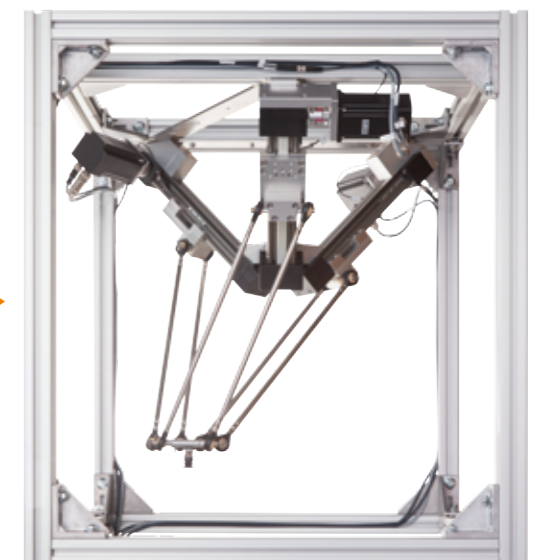
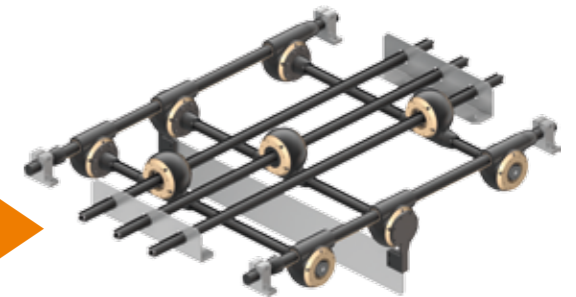

Buying your robot

- Flexible articulated arm robots for industry, educational institutions, and private use
- Delta robots for fast pick & place tasks.
- Linear robots (or XYZ robots) for modular automation
- If you wish, you can order a pre-configured control system for each robot.

igus.eu/low-cost-automation

Costs for a robot system: when does automation pay off?

The economy of an automation system depends not only on acquisition costs, but also on long-term costs, such as for peripheral devices, adjustments to existing machines, and installation costs.

A decisive factor is the comparison between an automated production system and conventional production without robots. What are the benefits of automation and robotics? **Support for employees:** with such benefits as physical relief and improved ergonomics **Flexibility:** individual adjustment to production facilities and processes **Reliability:** high technology reliability and low error rates **Speed:** handles large order volumes at peak times In addition to direct costs, the economic efficiency of a robot system also depends heavily on system quality and flexibility. Robots are characterized by their variable usability, which means that they can also be used for other tasks when production is changed. This usually greatly reduces investment costs for new production plants.

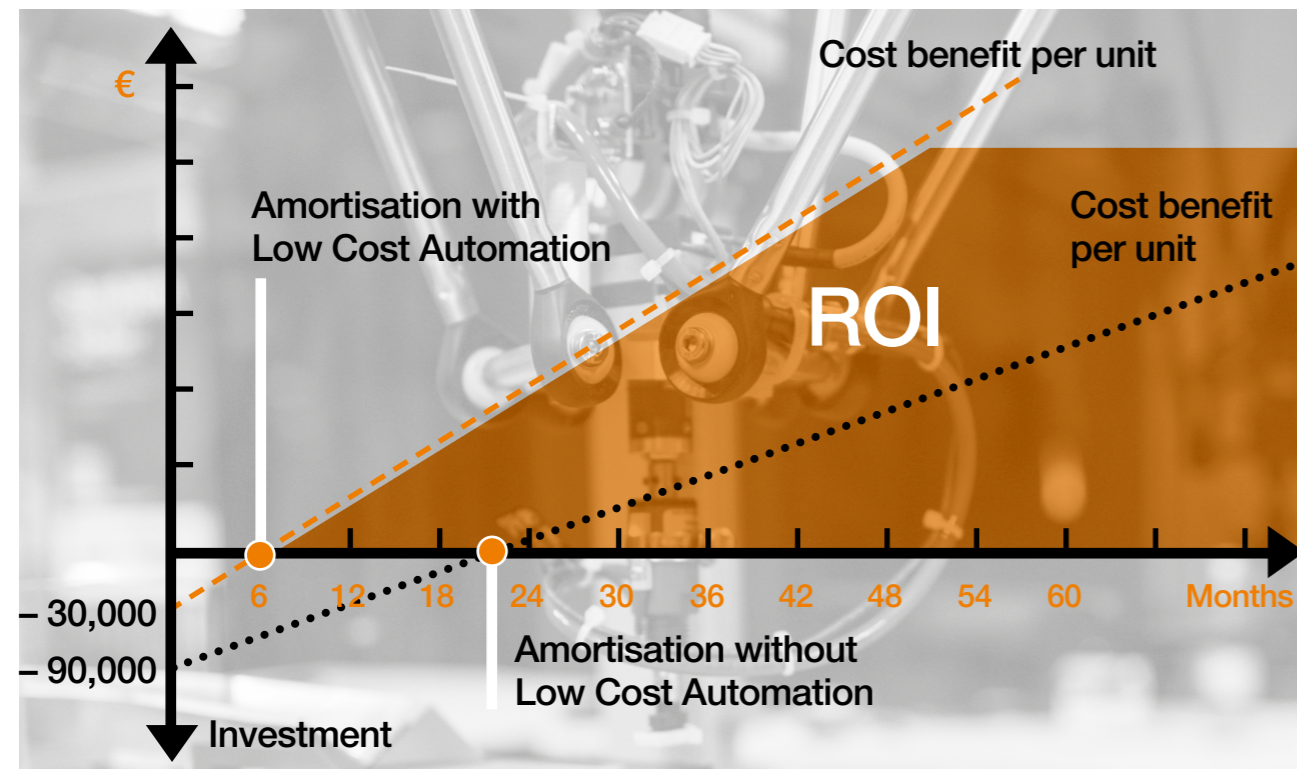

ROI: Return on Investment

Low Cost Automation creates an overall cost advantage of around 70 to 75%. Applications with Low Cost Automation take between 3 and 12 months to pay for themselves if the robot system meets payload and dynamic requirements.

Cost-effectiveness of automation solutions – the ABCs of costs

- ▶ **Operating costs**
Operating costs are calculated from maintenance, space, energy, personnel, tool, and auxiliary and operating materials costs. Since these costs depend on the production process, they can vary significantly over the period of use. Material, set-up, storage and disposal costs must also be taken into account.
- ▶ **Servicing costs**
Servicing consists of maintenance, inspection, and repair. Although these costs are affected by the type, duration, and frequency of servicing measures, these factors are also associated with the probability of unplanned machine downtime. Planned servicing is therefore subject to the conflicting objectives of high system availability and low servicing costs. For an initial approximation, a factor can be used to calculate servicing costs. A typical figure for annual servicing costs is 10% of system procurement costs.
- ▶ **Space costs**
The space the robot requires is defined by the system's reach and space requirements. Material flow and delivery strategy must never be ignored in this definition. If the robot system is surrounded by a safety fence, the area within the fence can be used for the space requirement. The periphery located outside this area should be taken into account.
- ▶ **Energy costs**
The costs for electricity and compressed air comprise a robot system's energy costs and are not constant over its service life. An automated system's main power consumers are the robot, the control system, and application-related equipment such as a welding table, welding power source or transformer, and the laser. In practice, the robot's energy consumption depends on size, reach, payload, acceleration, and travel speed.

Buy a plug & play robot or
build your own



igus.eu/low-cost-automation

The ReBeL[®] robot arm as an industrial and service robot

Lightweight ReBeL[®] robot prepared for human-robot collaboration applications

For the first time, a cobot will be added to the Low Cost Automation portfolio. Electronic components in the fully integrated ReBeL[®] strain wave gear allow HRC capabilities. The ReBeL[®] robot arm is thus suitable for:

- Suitable as cobot or service robots
- Mobile applications
- Collection and delivery services
- Pick & place tasks
- Assembling assistance
- Quality control
- Education area for university and school training purposes

Technical data:

ReBeL[®] robots

- Payloads of up to 2kg
- Reach of up to 664mm
- Application areas: industrial and private applications as cobot or service robots

igus.eu/rebel

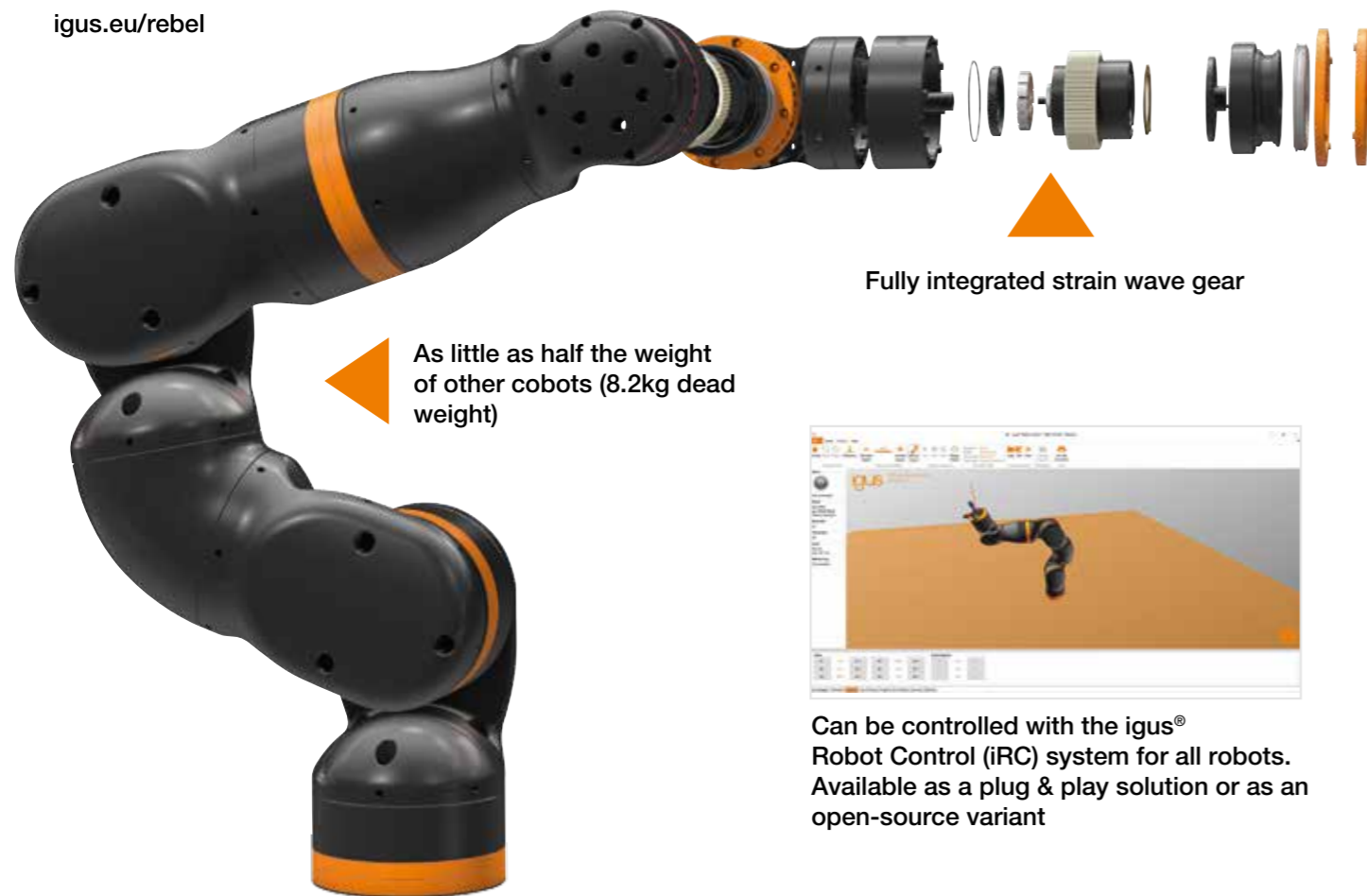

Fully integrated strain wave gear

As little as half the weight of other cobots (8.2kg dead weight)



Can be controlled with the igus[®] Robot Control (iRC) system for all robots. Available as a plug & play solution or as an open-source variant

No control cabinet - control system integrated in the base



igus.eu/Low-cost-automation

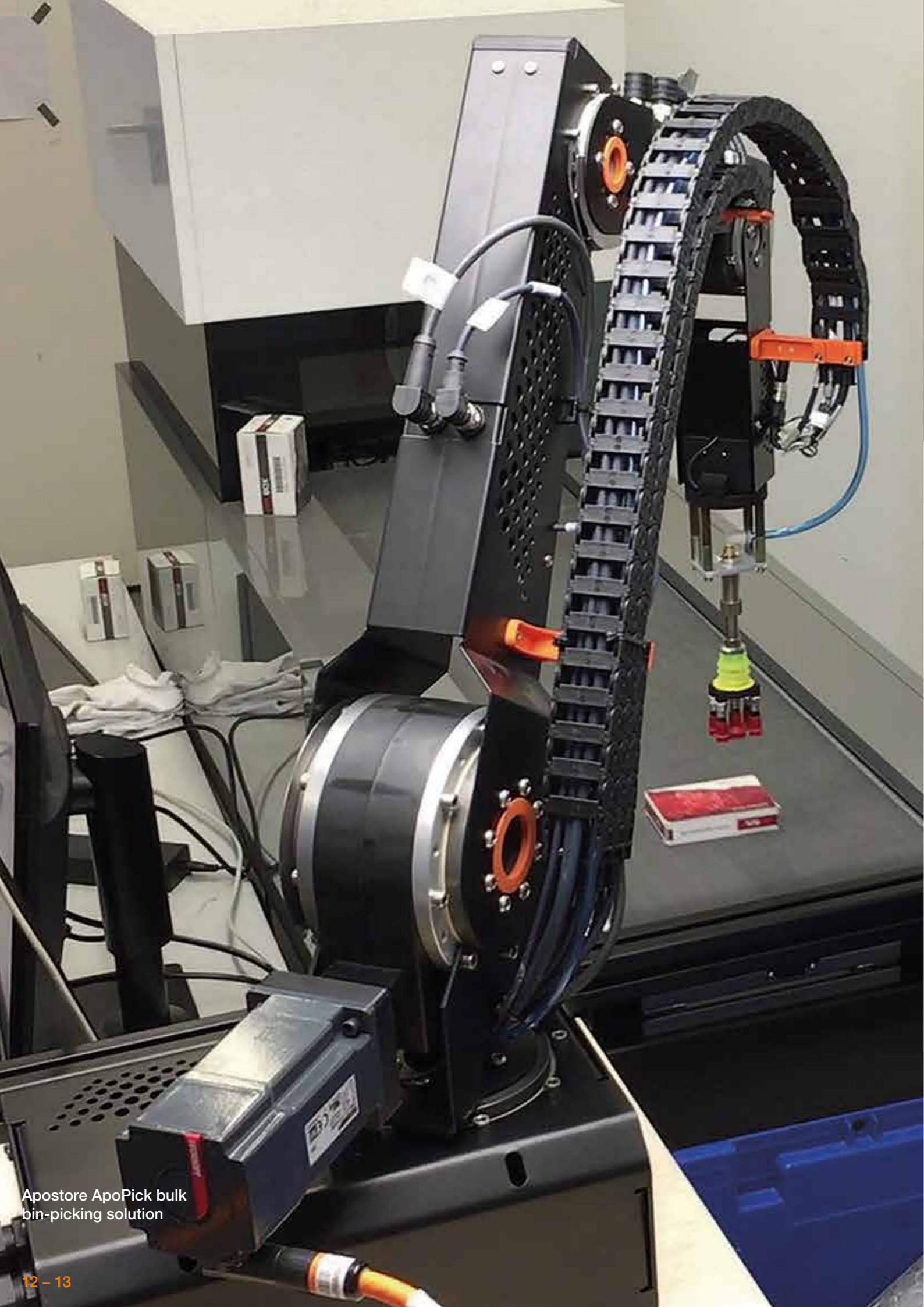

Bin-picking

The pick & place robot solution takes care of insertion 24/7 and features integrated delivery note management. The bulk pharmaceutical material is sorted autonomously into the chemist's inventory system, automating the entire process. The articulated arm robot is one system that can be used here.



**Amortisation:
about 6 months**



Technical data:
articulated arm robot

- Payloads of up to 3kg
- Reach of up to 790mm
- Application areas: flexible pick & place applications

igus.eu/roboLink



igus.eu/low-cost-automation

Robots in a packaging machine

Carefully grab and sort

The automated praline picker "Chocomatic" consists of a robolink® articulated arm robot that moves on a linear axis. The flexible workspace and integrated camera system allows the robot to automatically grip pre-selected pralines and carefully deposit them in a box. This application uses a robolink® DC and a drylin® toothed belt axis with energy chain.



**Amortisation:
about 8 months**

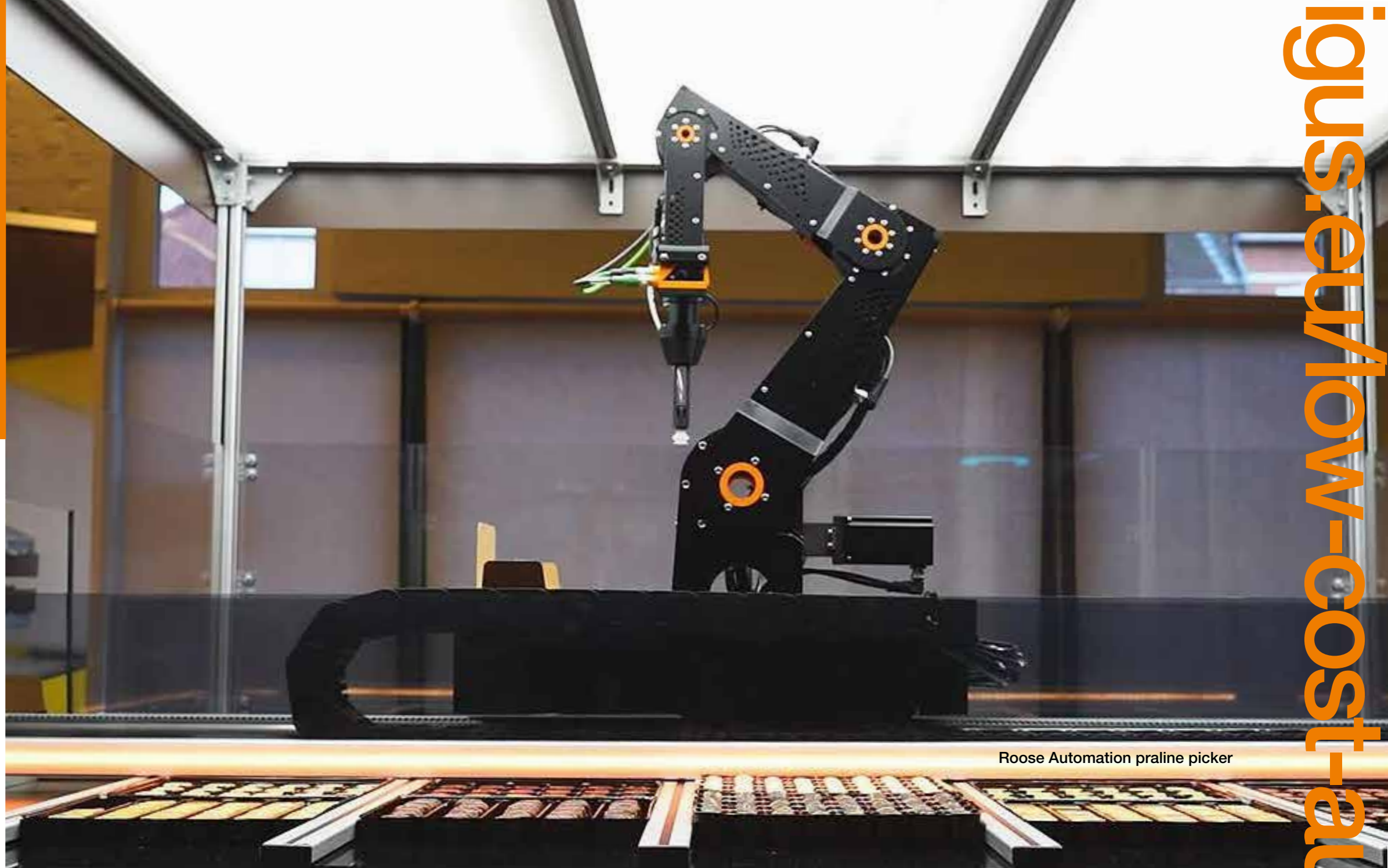

Roose Automation praline picker



Technical data:

drylin® ZLW seventh axis for all robots

- Maximum strokes: 3,000mm (up to 6,000mm depending on technical design)
- Max. speed: 200mm/s
- Precision: ±0.3mm



E2/000 energy chain, which can be opened from both sides in the inner radius. The E2/000 system: easy, versatile assembly and installation combined with robustness – high strength with quiet operation, long cable service life, and many mounting options

Quick, efficient sorting with pick & place delta robots

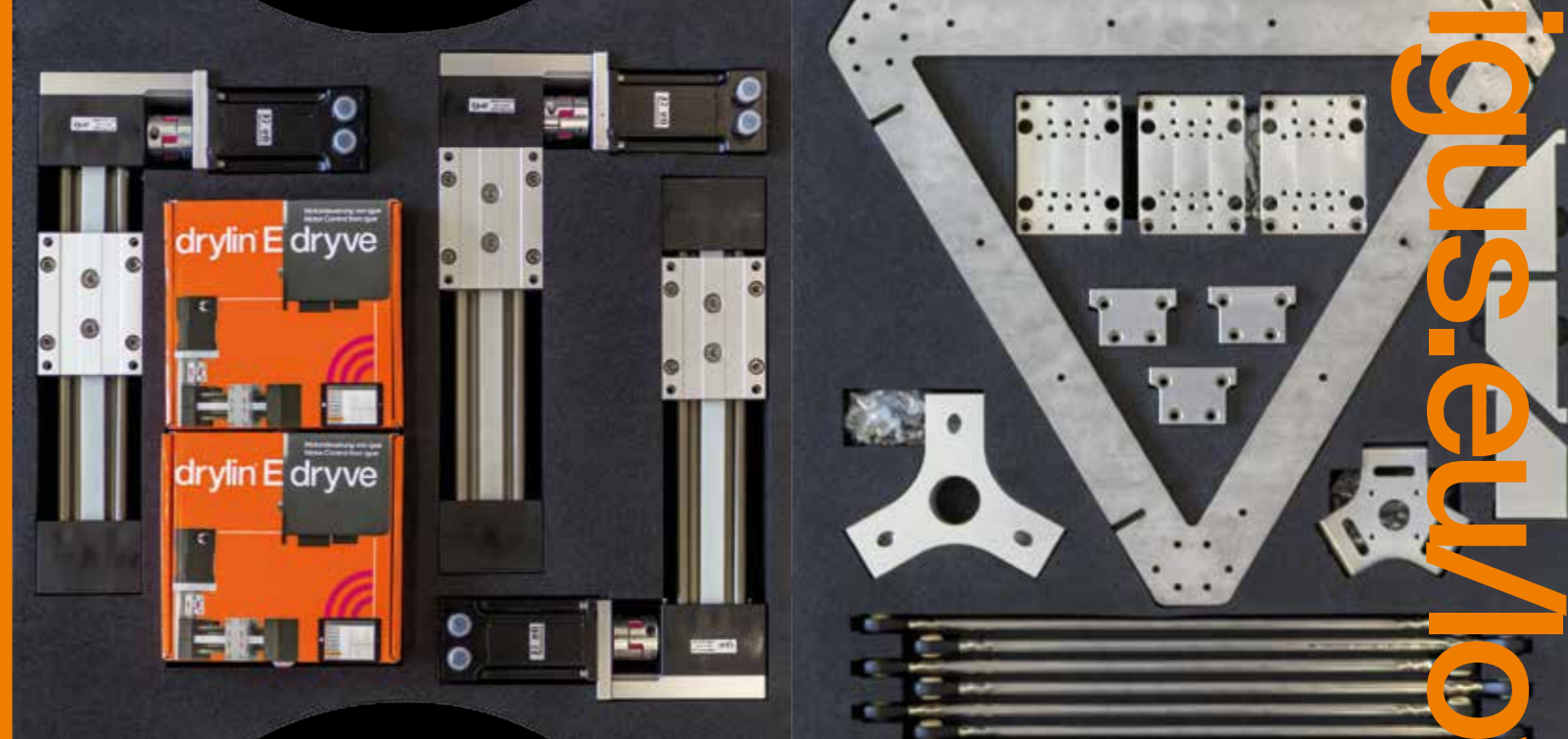

Available fully assembled or as a kit

Sorting for fire protection at Vetrotech Saint-Gobain

To produce fireproof glass, the delta robot sorts bulk material onto predefined pallets which then go through the manufacturing process. This frees up employees and significantly reduces costs. The robot system also allows more flexibility thanks to short set-up times and can be expanded as required. The delta robot with a working area of 360mm is used in this application.



**Amortisation:
about 8–12 months**

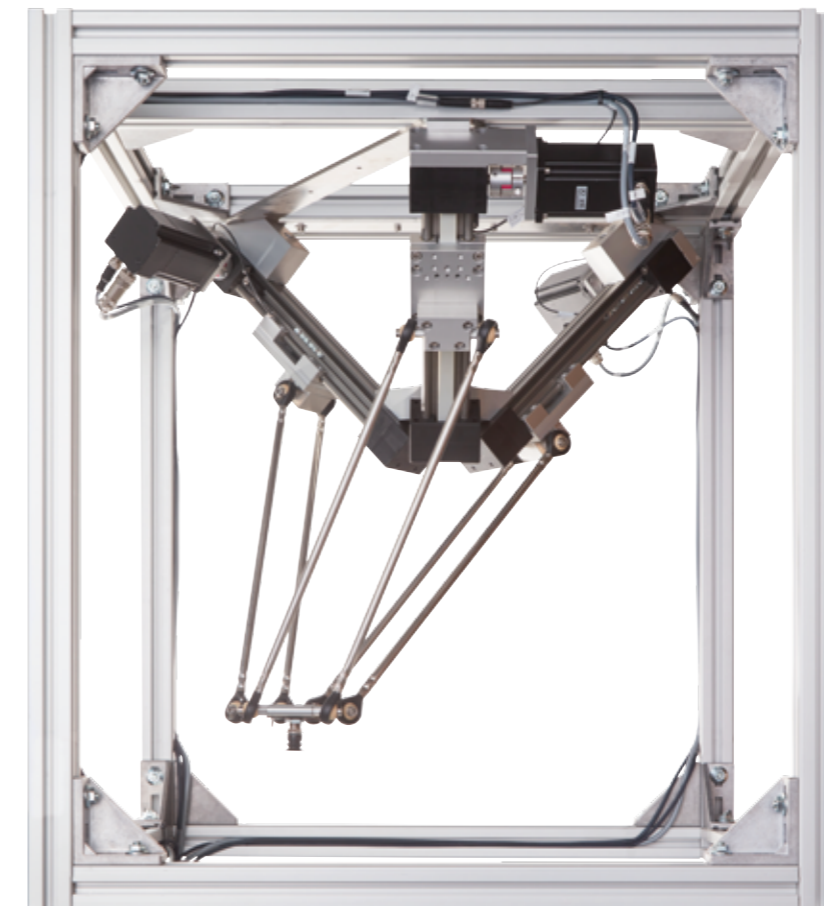

Technical data:
delta robots

- Payloads of up to 5kg
- Speeds of up to 3m/s
- Application areas: fast pick & place applications

igus.eu/delta

Vetrotech Saint-Gobain component pick & place onto predefined pallets



Agricultural automation: delta robot removes weeds chemical-free with laser

Ecological weed control

The lightweight, cost-effective delta has opened up new possibilities for these robots in mobile applications and demonstrated a new technology in a harsh outdoor environment. This application uses a corrosion-free delta robot with a working area of 660mm.



**Amortisation:
about 12 months**

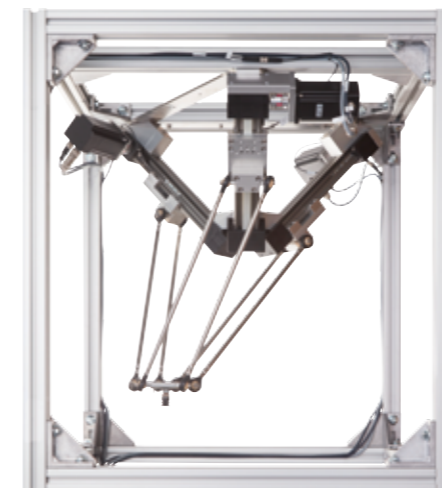

Technical data:

delta robots

- Payloads of up to 5kg
- Speeds of up to 3m/s
- Application areas: fast pick & place applications

igus.eu/delta

Dispensing processes: automated bonding and sealing

Our dosing and bonding robots bond components with the highest precision, ensuring consistent quality. The processes can be repeated exactly.

The robot's user-friendly set-up and control system and modular concept governing our robotics components allow the bonding processes to be adapted flexibly. The robot is also available as a complete solution with frame and CE marking. The compact DLE-RG-0001 room linear robot is used.



**Amortisation:
about 6 months**

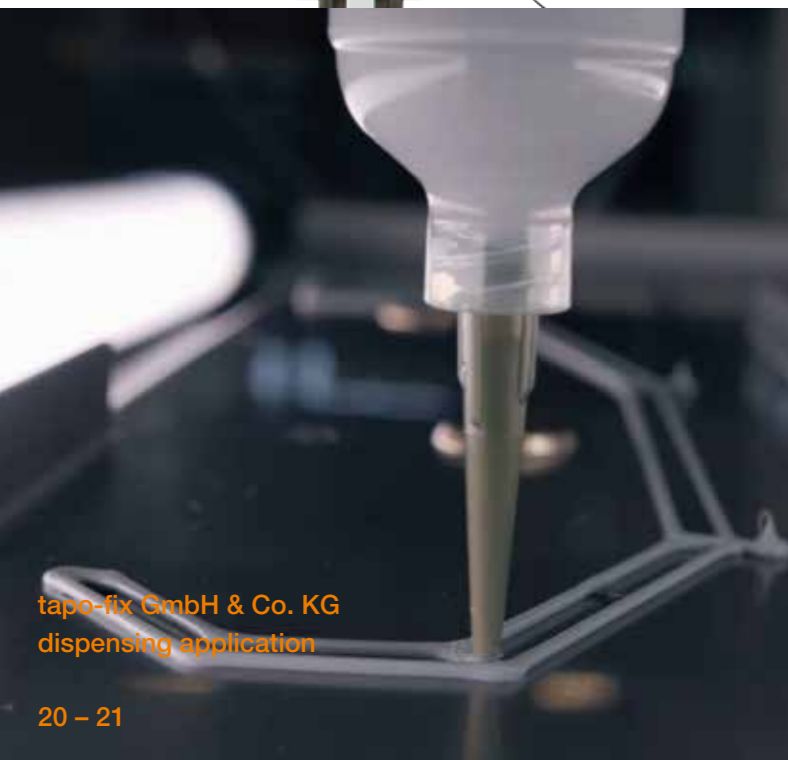
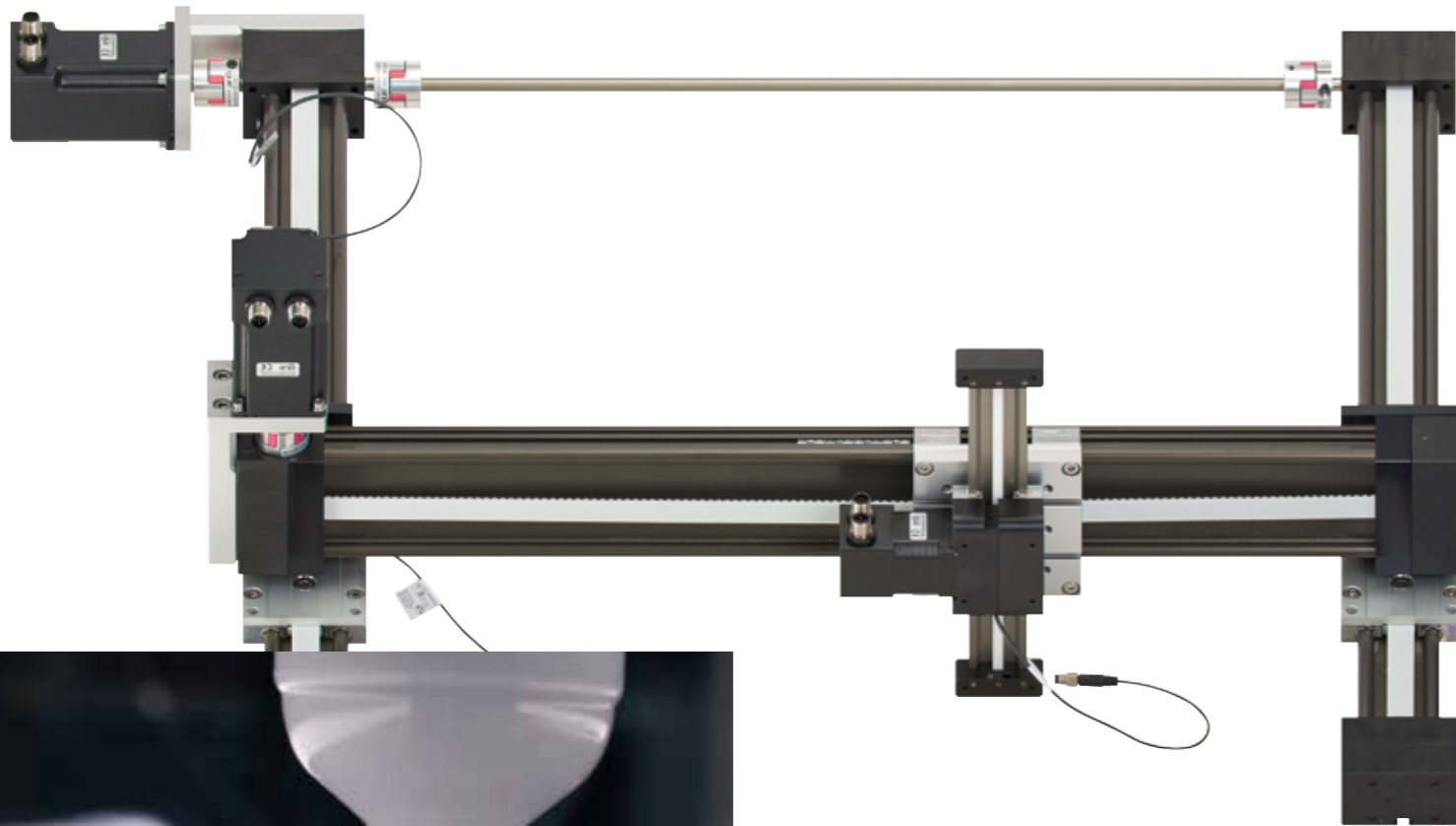

Technical data:

linear robots

- Payload: up to 10kg
- Repeatability: $\pm 0.2\text{mm}$
- Speeds of up to 1m/s

igus.eu/linear-robots



igus.eu/low-cost-automation

Individual linear robot: describe the application, receive an offer

Robust, customisable, and lightweight

drylin® linear robots consist of various linear actuators that perform xyz linear movements. The lubrication-free components are corrosion-free, maintenance-free, and lightweight. drylin® linear robots cost up to 60% less than conventional linear robots.

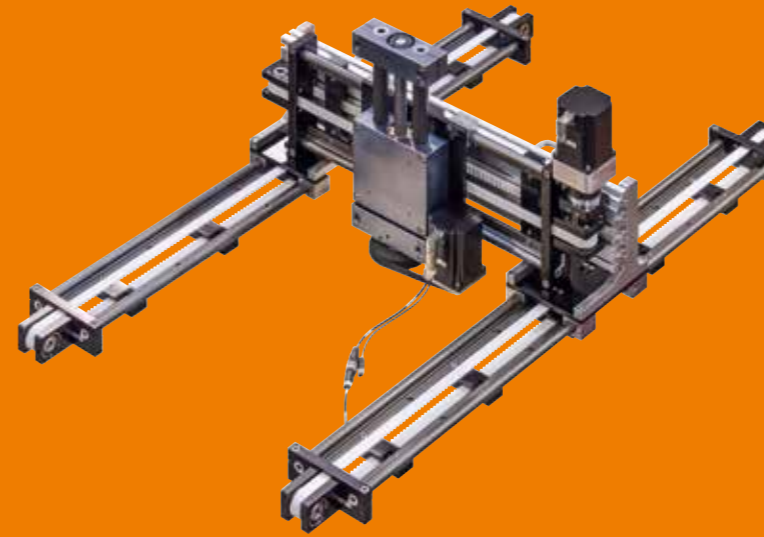

Particularly resilient

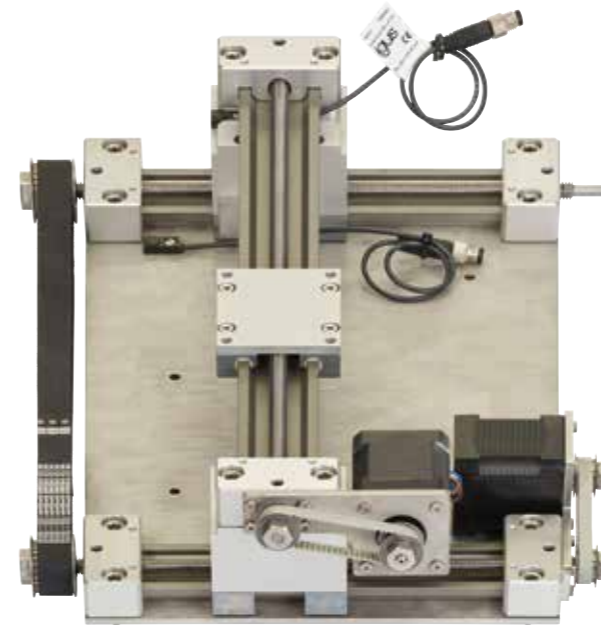
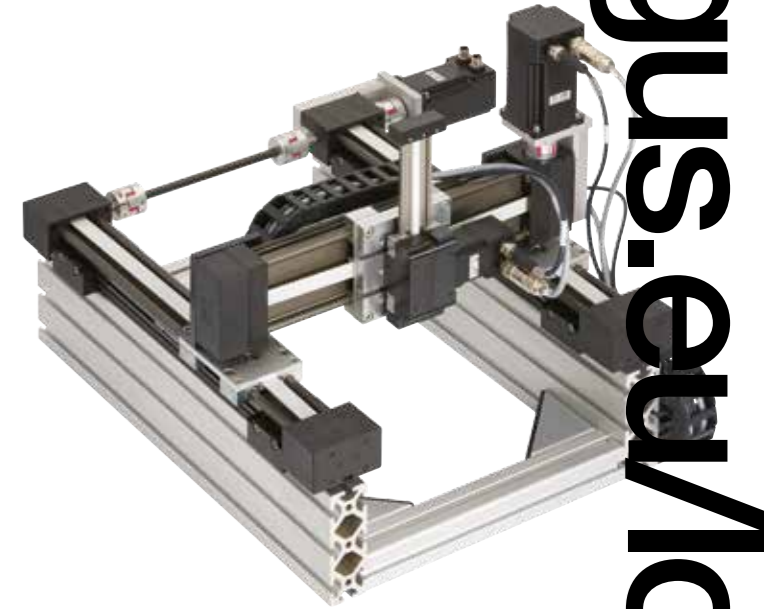

Particularly individual



KamerMaker XXL 3D printer

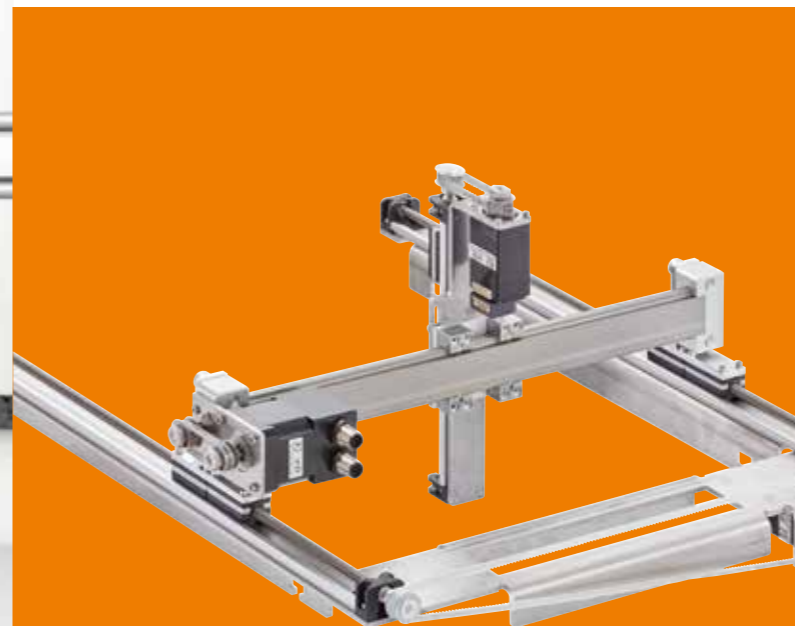

Particularly lightweight

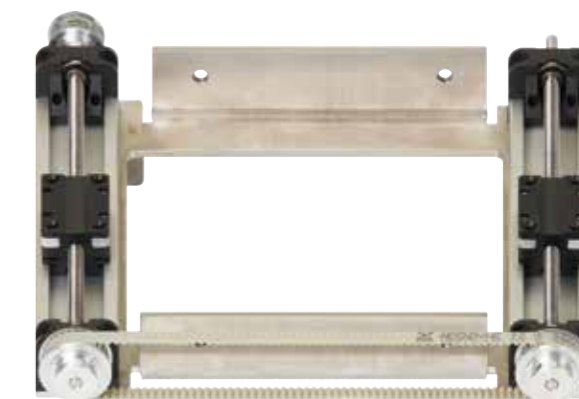

igs.eu/low-cost-automation

The heart of your robot: gearboxes with or without motor for flexible, multifaceted applications

From robot to format adjustment – modular construction kit for robotics, cobots and automation solutions

- Worm gears, strain wave gears, planetary gearbox
- Modular
- With and without motor
- Lightweight construction
- Areas of application: flexible automation solutions, robot and cobot construction

igus.eu/drygear



Amortisation:
about 4 months

Robot modular gearbox system

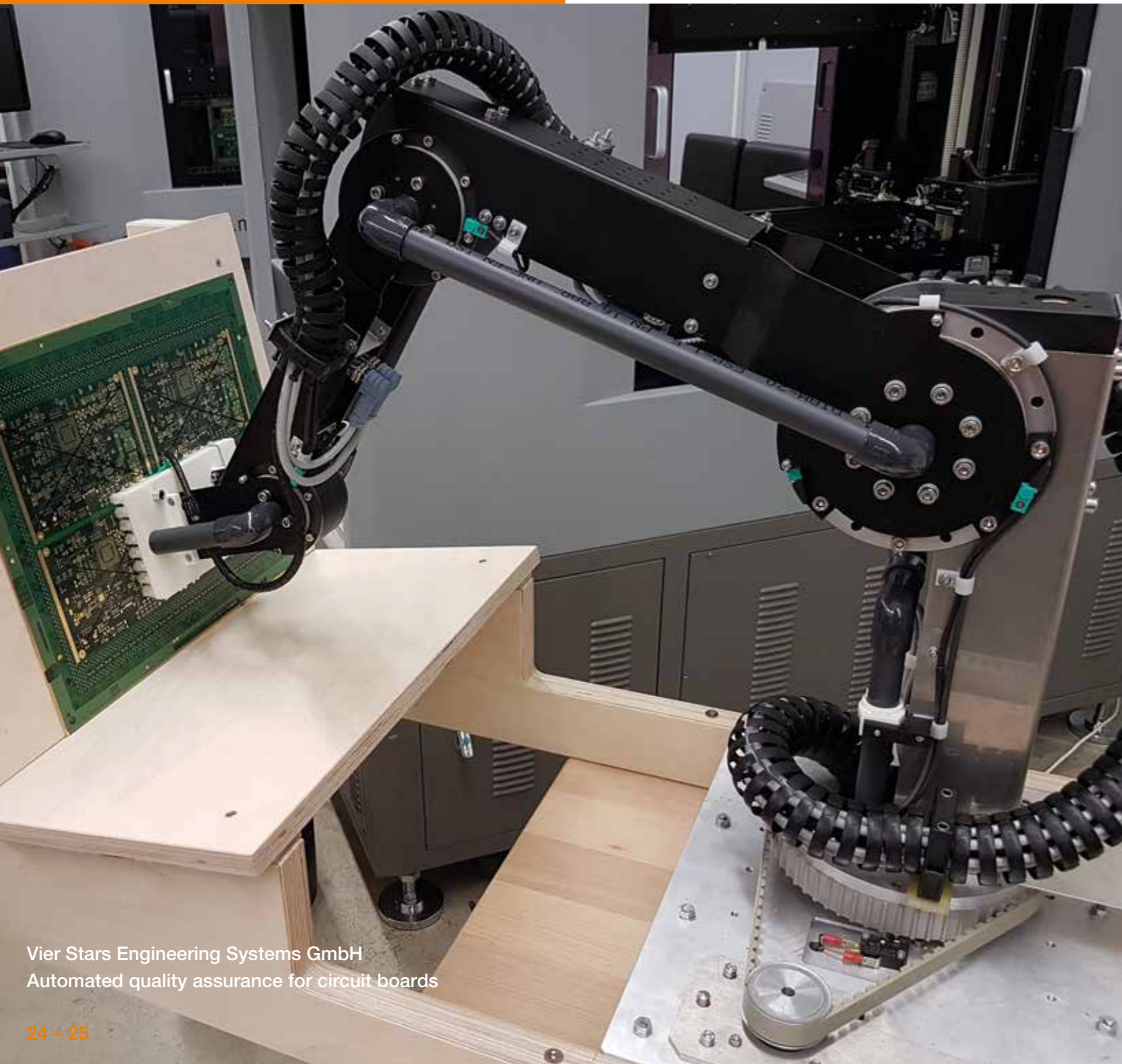
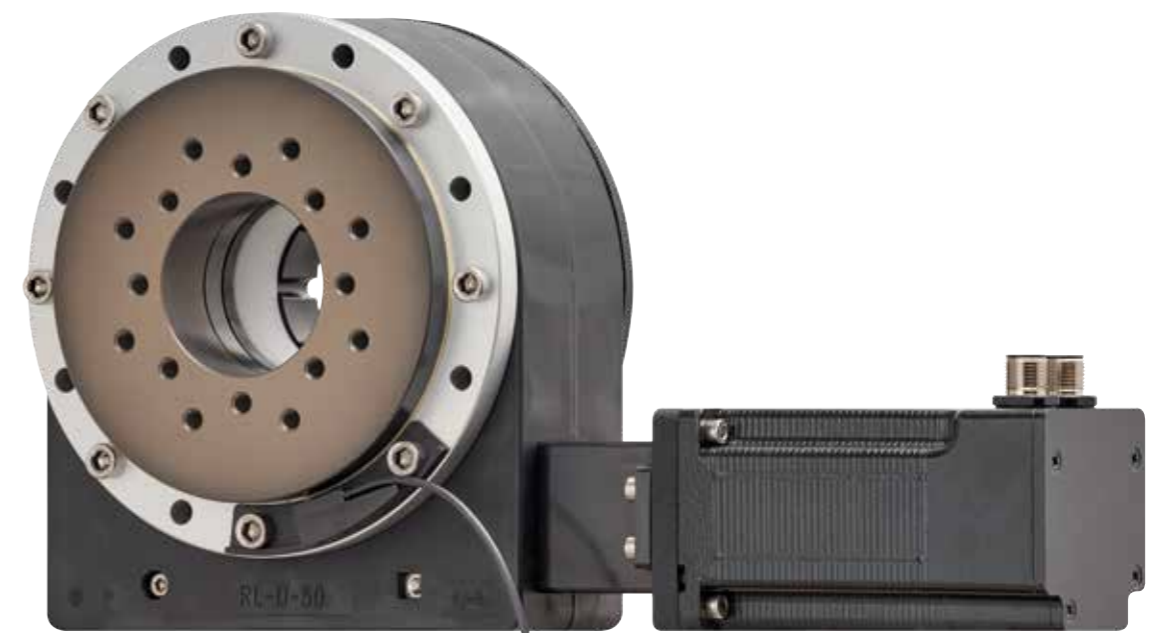

igus.eu/low-cost-automation

ReBeL[®] gearbox
for industry and
service robots.
Build or buy



Build your own robot kinematics with fully integrated individual joints.

Based on the ReBeL[®] gearboxes, an individual robot can be designed with connectors, and thanks to the additional electronic components, it can also be implemented as a cobot. The gearbox can be used, for example, in the last axis of articulated arm, linear, and delta robots with various gripper systems.

Technical data:

ReBeL[®] fully integrated strain wave gear

- Fully integrated individual gearbox with motor and control system
- Output with encoder and mounting flange
- Brushless DC motor (external rotor)
- CAN-BUS motor driver board
- 25% lighter than conventional strain wave gears thanks to igus[®] high-performance polymers

igus.eu/rebel

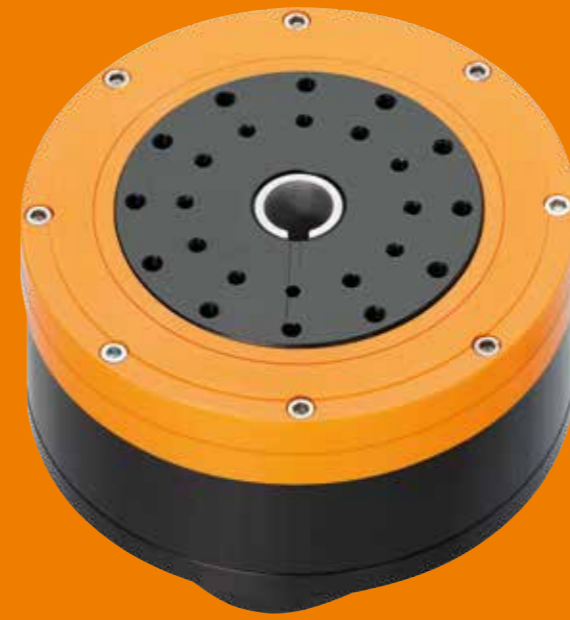

igus.eu/low-cost-automation

Apiro® robot iDeas

Our Apiro® gearbox system for a wide variety of kinematic elements and superstructures was named after the Greek word for "infinite". It allows modular, cost-effective implementation of individual applications.

Typical areas of application are

- Lane adjustments
- Pusher tasks
- Gears with different ratios
- Rotary tables and rotary axes

igus.eu/apiro



From a single part to a complete robot

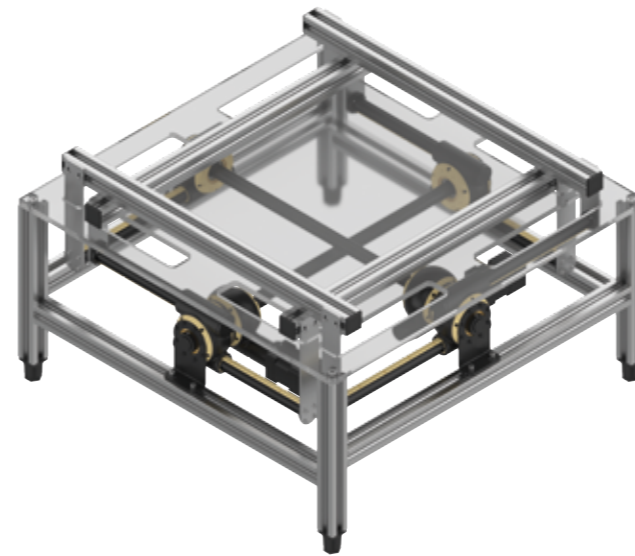

igus.eu/low-cost-automation

Fast, flexible and configurable: SCARA robot

Ideal for simple robotics and assembly tasks

The SCARA robot for fast, flexible use. Typical application areas include assembly and joining tasks in the electronics industry, for example. In most cases, it is used for loads of up to 2kg.

 **Amortisation: about 6 – 8 months**

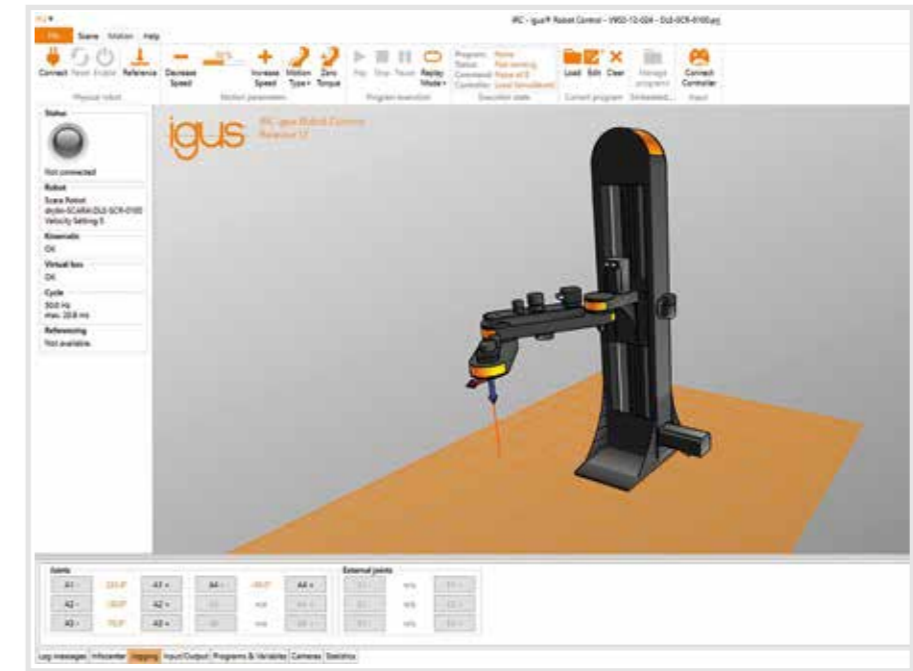
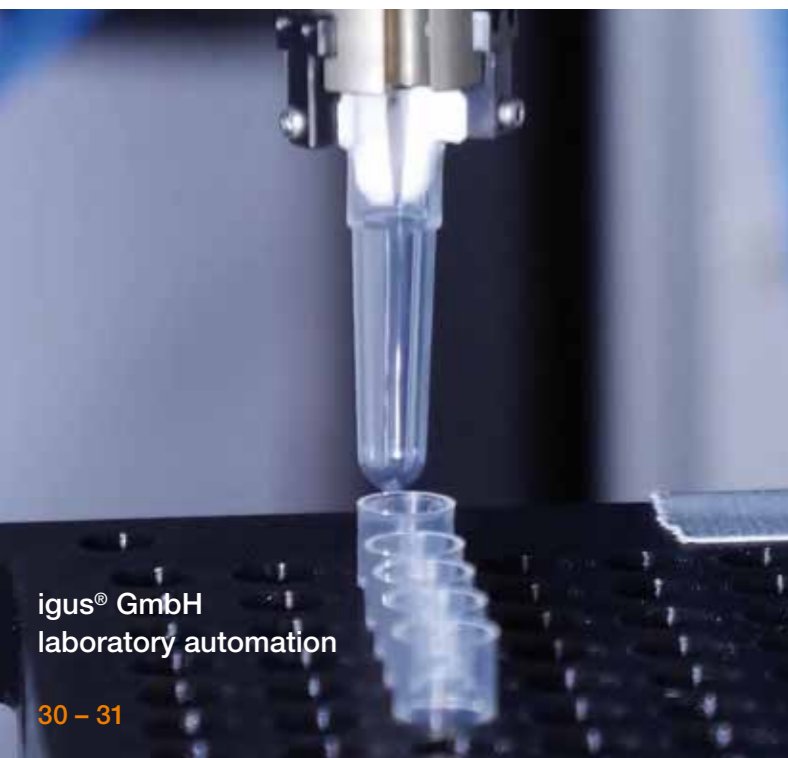

Program and test a SCARA robot free of charge in advance. The drylin® SCARA robot is compatible with igus® Robot Control. The relevant software can be downloaded and tested free of charge in advance. It's easy to program your SCARA robot solution.

igus.eu/irc

Technical data:

SCARA robots for process speeds starting at three seconds

- 4 DOF (degrees of freedom)
- IP44 version possible
- Fully integrated into the igus® Robot Control software
- Splash-proof variants available



igus.eu/low-cost-automation

Intuitive robot control system with the free igus® Robot Control

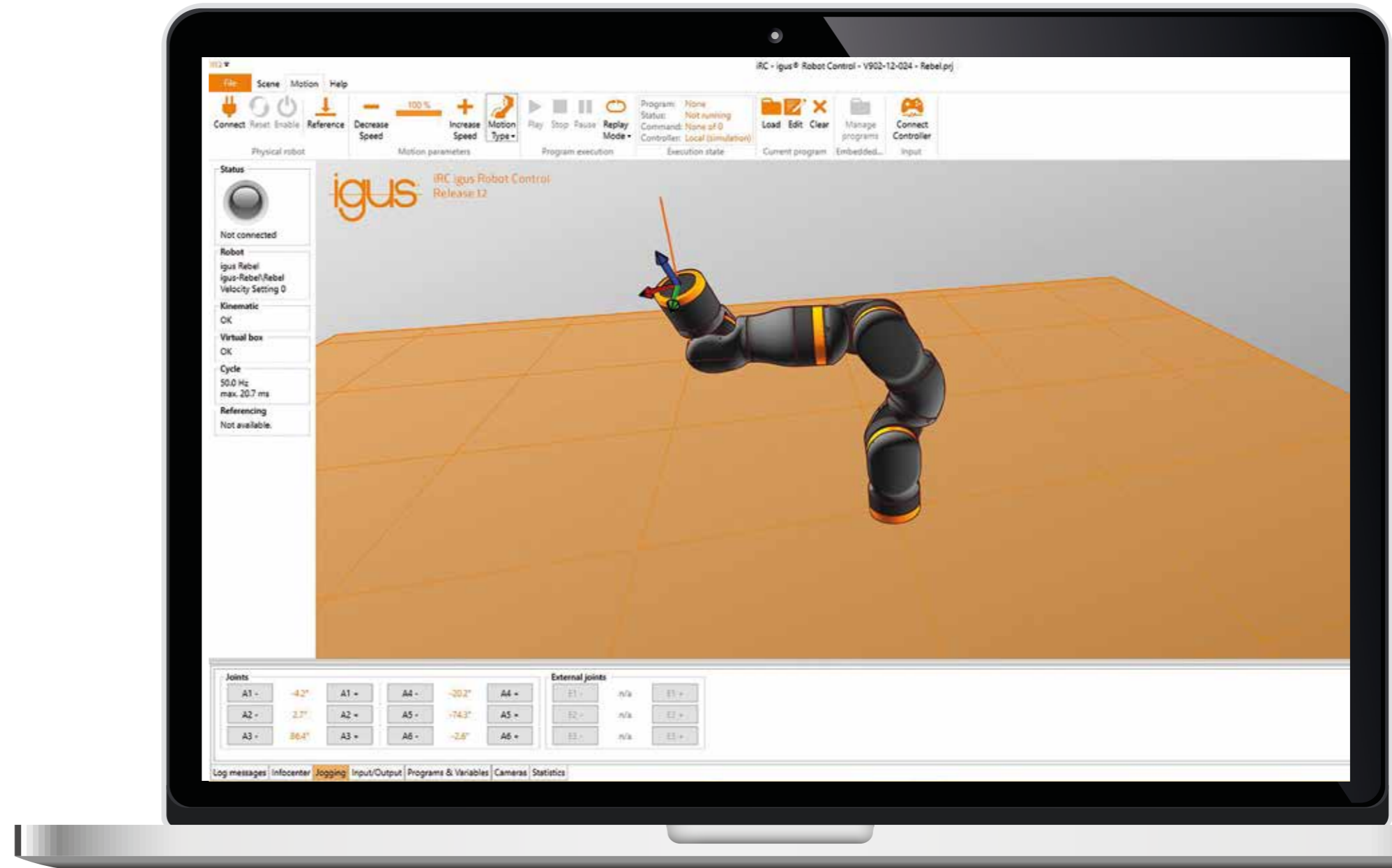

Technical data: control system for all igus® kinematics

- Test robots with a digital twin before you buy
- Free software download
- No programming expertise required, user interface similar to well-known office programs
- Can be programmed with gamepad or handheld control function
- Use with Windows 10 operating system or download as an app
- Preconfigured projects for all igus® robots, SCARA, delta, single axes, AGVs, and much more
- Robot can be controlled with a smartphone
- Gripper and camera integration included
- Custom design (optional)



Download here: www.igus.eu/iRC

Low-cost robotics technical data



Articulated arm robot

- Payloads of up to 3kg
- Reach of up to 790mm
- Application areas: flexible pick & place applications

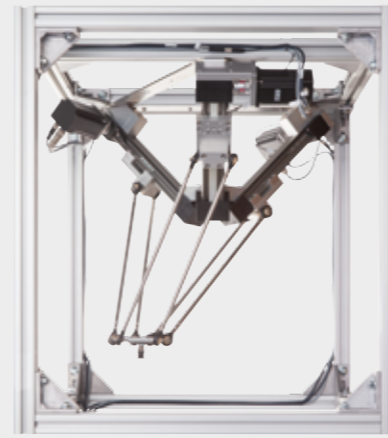

Delta robot

- Payloads of up to 5kg
- Working area diameter of up to 660mm
- Speeds of up to 3m/s
- Application areas: fast pick & place applications

Linear robots

- Payload: up to 10kg
- Repeatability: $\pm 0.2\text{mm}$
- Speeds of up to 1m/s

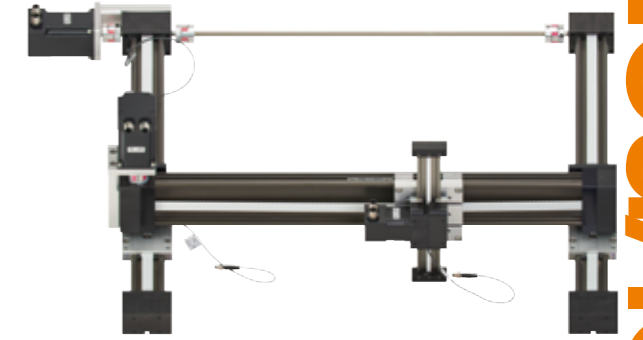

SCARA robots for process speeds starting at three seconds

- 4 DOF (degrees of freedom)
- IP44 version possible
- Fully integrated into the igus® Robot Control software
- Splash-proof variants available
- Payloads of up to 2kg
- Reach of up to 560mm

drylin® ZLW, seventh axis for all robots

- Maximum strokes: 3,000mm (up to 6,000mm depending on technical design)
- Max. speed: 200mm/s
- Precision: $\pm 0.3\text{mm}$
- Adaptable to all igus® robots, but also robots from UR, ABB, and many more

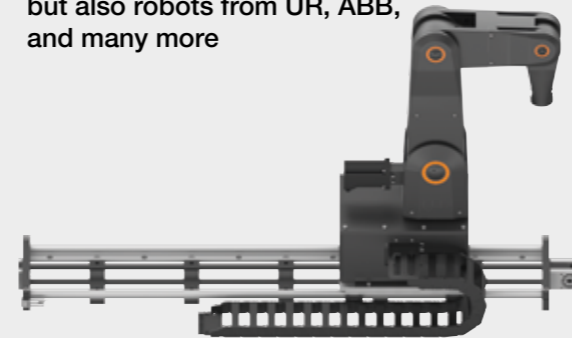

ReBeL® robots

- Payloads of up to 2kg
- Reach of up to 664mm
- Application areas: industrial and private applications as cobot or service robots

Modular construction kit for robotics, cobots and automation solutions

- Modular
- Fully integrated gearbox with motor, control system and encoder
- Lightweight construction areas of application: flexible automation solutions, robot and cobot construction



igus® Robot Control (iRC)

- Free software download
- No programming expertise required
- Can be programmed with gamepad or handheld control function
- Available for all robot kinematics



drygear® Apiro® modular gearbox system

- Payloads of up to 2kg
- Available transmissions: 4:1, 32:1, 64:1
- Output torque: 2.5Nm
- Stroke: 60–1,050mm
- Areas of application: lane adjustments, pusher tasks, rotary tables, and rotary axles



Assembly kit for room linear robots

- Includes three D1 motor control systems
- Areas of application: control of linear and rotary drives
- Easy initial operation

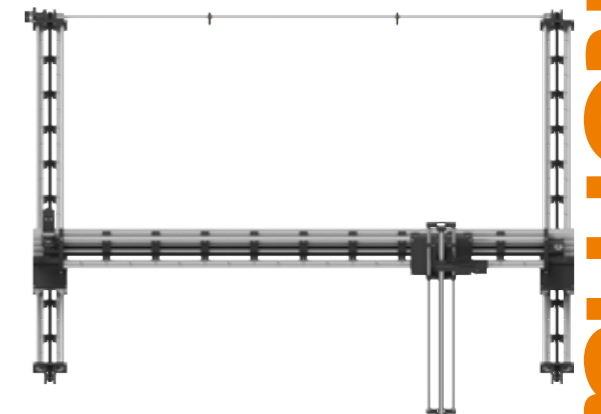

"XXL" room linear robot

- Workspace: 2,000 x 2,000 x 1,000mm
- Payload of up to 10kg
- Precision: $\pm 0.8\text{mm}$
- Speeds of up to 500mm/s

Introduction to the world of automation



Which factors are important in the purchase of a robot system?

You must select the right kinematics for your automation with great care if you are to plan safely in the long term and avoid unnecessary set-up costs.

Keep costs to a minimum

In addition to hardware costs (robots, grippers, etc.), it is imperative that other costs be considered, such as those for safety technology, maintenance and repair, CE certification, sensors, programming, and operating costs. The right kinematics limit acquisition costs and pay for themselves in the shortest possible time.

Long-standing support

Companies investing in automation systems want long-term support from the manufacturer. The Low Cost Automation team provides long-term support and spare parts service, guaranteeing customers maximum planning security.

How do I select the right kinematics for my application?

There are many factors that influence robot selection. The most important are:

Required accuracy at the operating point



Process cycle time



Payload

The maximum allowable load that a robot can handle in addition to the tool load. Robots are divided into small-load, medium-load, and heavy-load robots based on their maximum load.



Reach and nominal reach

Nominal reach is the working space in which the robot can work in the long term. In the short term, the robot can also operate within its maximum reach.



Degrees of freedom

Degrees of freedom indicate how many independent driven movements a workpiece or tool attached to the robot can perform in relation to a fixed coordinate system.

Low Cost Automation – checklist

Your data

Name _____ Date _____
 Company _____ Telephone _____
 Contacts _____ E-mail _____
 Application _____

Required information

Quantity/batch size _____ Single application Volume application
 New design Technical improvement Cost reduction

Application data

Duty cycle _____ % Speed _____ m/s Reach _____ mm
 Cycle time _____ s Payload _____ kg Degrees of freedom _____

System design

Line robot Flat linear robot Room linear robot Articulated arm Delta robot

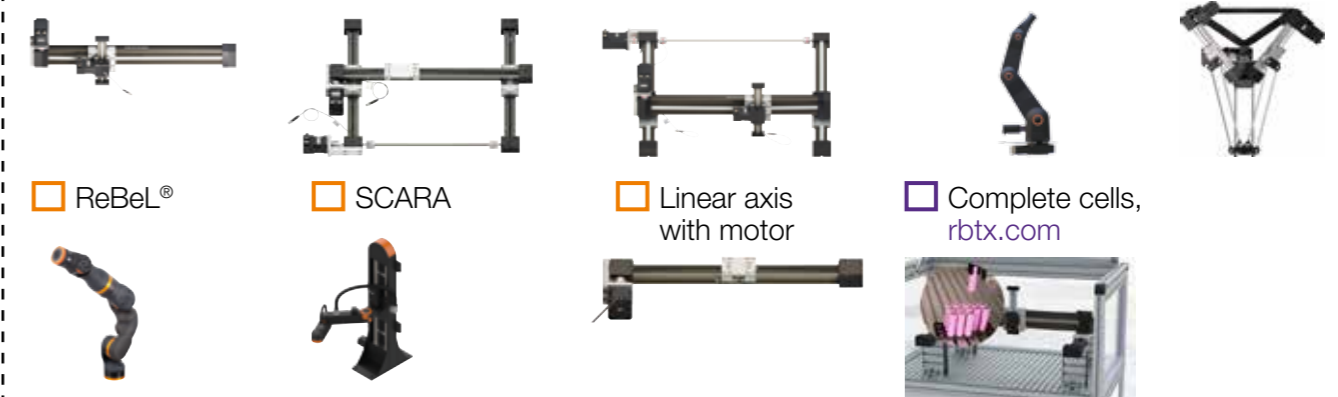

Installation position

Horizontal Vertical Lateral Overhead

Required accuracy (at the operating point) _____ mm

Ambient temperature _____ °C

Humidity Yes No

Notes/application description



Low Cost Automation – checklist

Control systems iRC



Motor control system



e-chains®

e-chains® Yes No

Additional services Yes No (such as pneumatic/electric)

Customer Testing Area

Do you have recent pictures or video of the application?

(If so, please send them to us. If not, please describe your application below).

Yes

No

If you have a video, do you consent to it being published?

Yes

No

Which accessories are to be tested with the robot?

Camera Gripper Control systems Other: _____



igus® Corner

I would like to pre-order an igus® Corner with product samples for testing. More about the igus® Corner at: igus.eu/corner



Planning and framework conditions

Preparation for successful deployment. If you are planning to use a robot for any application, you should first carefully consider the existing framework conditions. The fundamental questions can be broken down into a few core issues.

- ▶ **Degrees of freedom**
Number of available robot degrees of freedom (DOF)
- ▶ **System**
Stationary or non-stationary system (robot mobility)
- ▶ **Precision**
Required precision or repeatability at the end effector (requirements for the component that interacts with the environment)
- ▶ **Payload**
Robot payload on the end effector
- ▶ **Working space**
Required workspace
- ▶ **Speed**
Travel speeds and number of movement cycles
- ▶ **Flexibility**
Modular flexible configurability for the entire system (including subsequent conversion options)
- ▶ **sensor technology**
Required sensors for environment monitoring
- ▶ **Compatibility**
Programming and compatibility with existing control systems
- ▶ **Quality**
Workmanship quality and protection against environmental influences
- ▶ **Costs**
Investment and maintenance costs
- ▶ **Feel free to contact us.** We would be happy to provide you with free consulting on the kinematics best suited to your application.

Automate your applications in four steps



1. Book free live consultation with our experts

Free live video consultation with our automation experts at your preferred time. Show us your application, and we will find the right solution for you.



2. Show us your application, and we will check its feasibility

Feasibility testing for various kinematics. Send us your workpiece (mask, etc.).



3. Together we will find the necessary components

Free quotation including a binding fixed price for hardware components (this example is a mask dispenser, €6,947 and integration work of less than 100 hours – for this project 44 h). You receive a parts list tailored to your application.



4. You will receive a fixed-price offer for all components and their integration

Delivery of your individual solution and the hardware from your consultation, including live-remote commissioning.

<https://rbtx.de/rbtxpert>

Test before you invest – Customer Testing Area

Workpiece test for your desired application. Your benefits:

- Exceptionally fast feasibility analysis without your own setup
- With accessories such as grippers or vision sensors
- Direct testing with your workpiece in our robot cells
- Individual consulting with automation experts
- Fixed price with a parts list

The RBTX online marketplace has the right accessories for your application: www.RBTX.eu



Over 10,000 robots in use



Online tools: roboLink® online designer and linear robot configurator

ReBel® configurator

- Configure articulated arm robots online
- Intuitive CAD interface
- Parts list output
- Simulate movement for the entire robot
- "Teach" function for learning movement sequences with several intermediate steps
- Maximum range, movable weight and calculable workspace
- Also configure the linear axis as a seventh axis



www.igus.eu/rebel-configurator



Linear robot configurator

- Configure an individual drylin® linear robot and receive CAD data
- Live price display for individual workspace with and without a control system
- Program the robot's digital twin directly online and test the application
- Save time: configure your individual linear robot in just five minutes
- Other accessories with rack or grippers



www.igus.eu/linear-robot-configurator

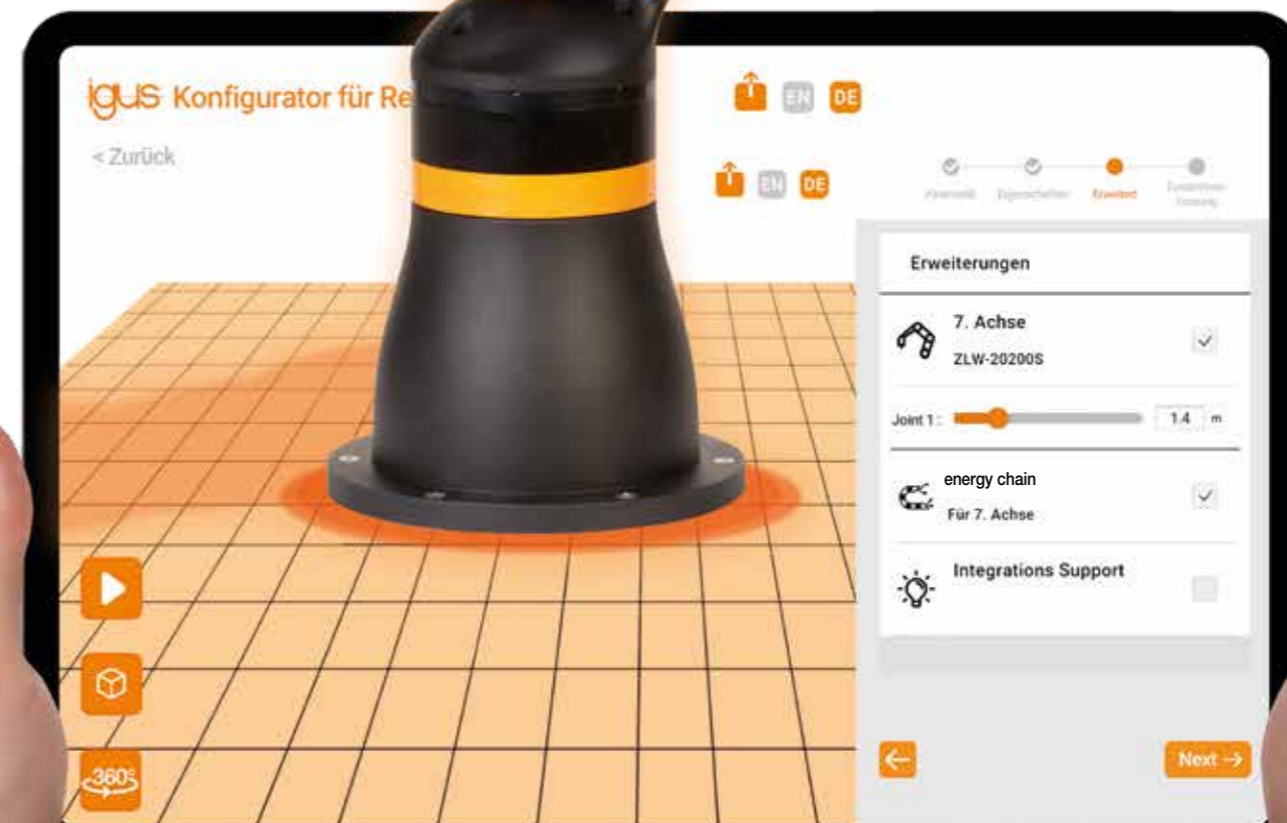

More than 8,000 individual solutions per year – there for you all over the world

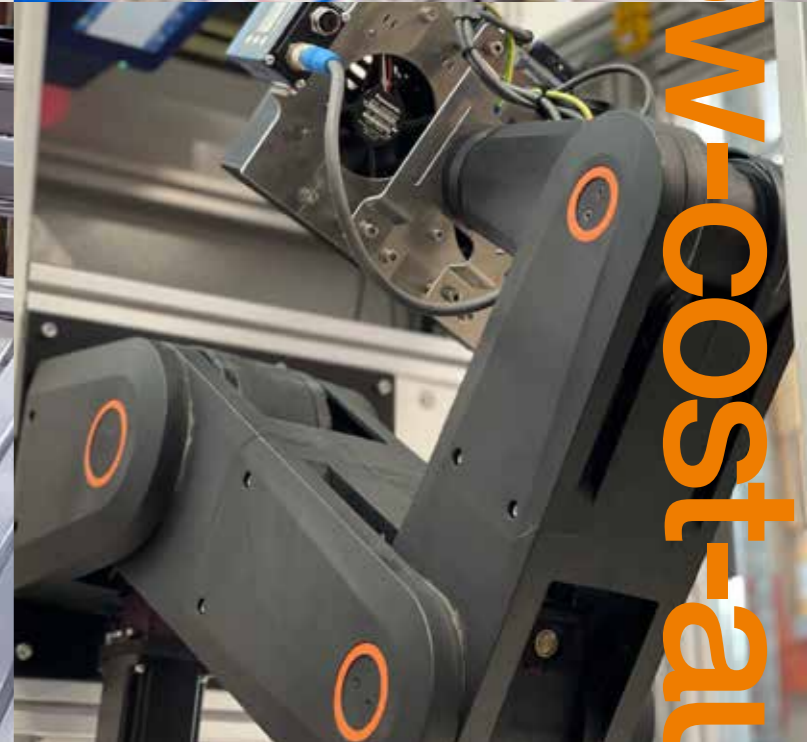
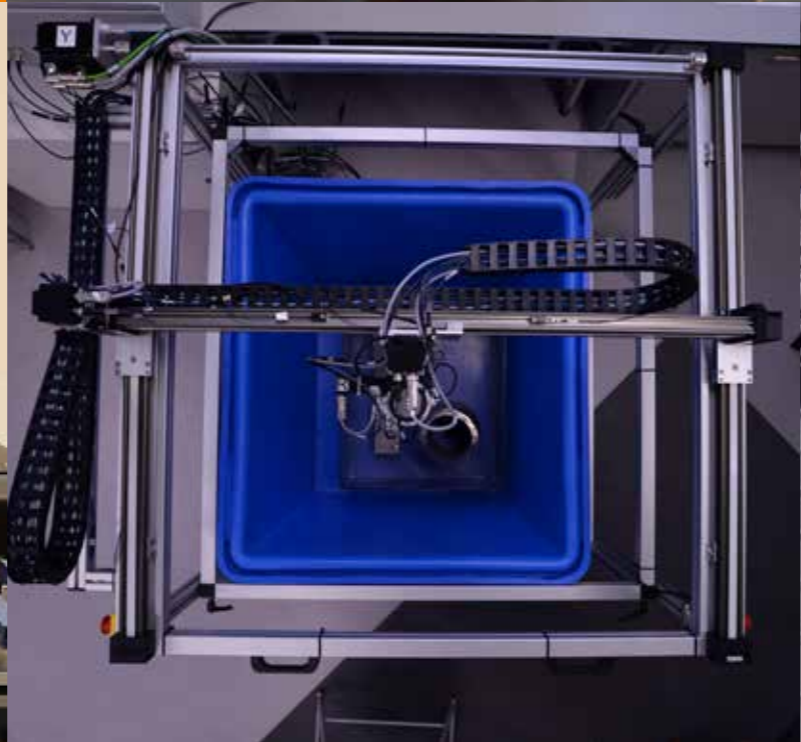
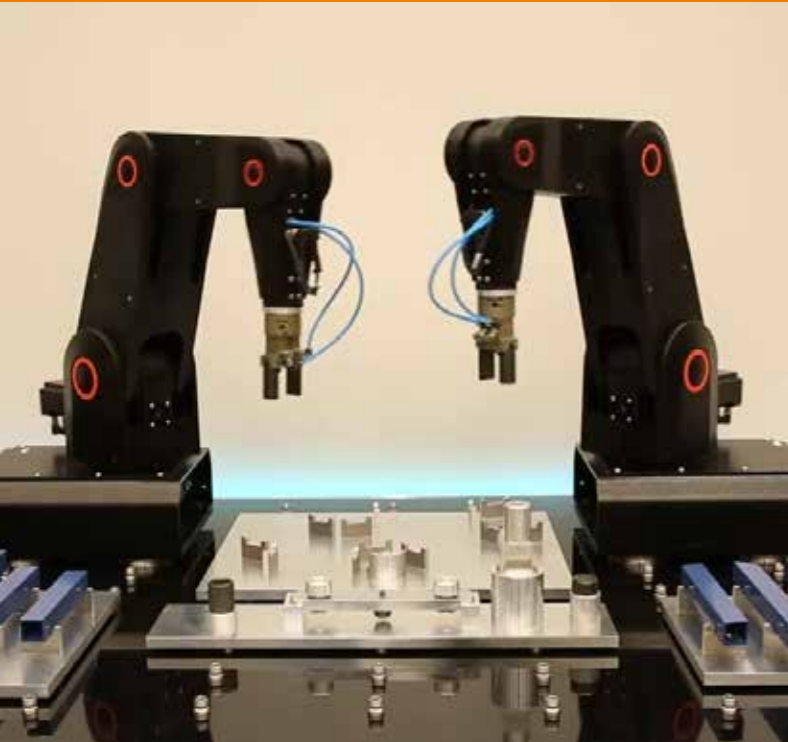

iguis.eu/low-cost-automation

Low Cost Automation.
Do more with less.
Start now!



e-mail: de-lowcostautomation@igus.net
Phone: +49 2203 9649-8255



Service



Personal consultation on site or online



In-house trade show at your site



Training measures



Workpiece testing



Project planning

igus.eu/low-cost-automation

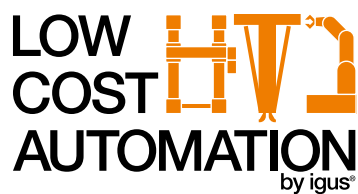

igus® GmbH
Spicher Str. 1a
51147 Cologne, Germany
Phone: +49 2203 9649-8255
info@igus.de
www.igus.eu

igus® is certified in accordance with ISO 9001:2015 and IATF 16949:2016 in the field of energy supply systems, cables and harnessing, as well as plastic bearings.

Legal information: The information in this brochure, and the technical data in particular, is based on our current knowledge of the products described [as of 10/2022]. The information in this brochure does not constitute legally binding assurance of specific properties or of suitability for a specific purpose. Due to constant technical refinement, we reserve the right to make technical changes to products at any time. Subject to errors and printing mistakes. Our offers are directed to traders/resellers only. The delivery times indicated reflect the time until the goods are dispatched; transport costs are not included in the price. We recommend that you always conduct a practical trial to check product suitability for a particular purpose. Contact us for advice. **Copyright:** The articles and diagrams published in this brochure are protected by copyright. Any use not permitted by copyright law requires prior written consent from igus® GmbH. This specifically includes copying, editing, translation, storage, processing, and reproduction of content in other (electronic) media, databases, and systems. The terms "igus", "Apro", "CFRIP", "chainflex", "chains for cranes", "conprotect", "CTD", "drygear", "drylin", "dryspin", "dry-tech", "easy chain", "e-chain", "e-chain systems", "e-ketten", "e-kettensysteme", "e-loop", "e-skin", "e-spool", "flizz", "ibow", "igear", "iglidur", "igubal", "igumid", "kineKIT", "manus", "motion plastics", "pikchain", "plastics for longer life", "print2mold", "readycable", "readychain", "ReBeL", "roboLink", "speedigus", "tribofilament", "triflex", "xirodur", and "xiros" are protected by trademark laws in the Federal Republic of Germany and also internationally, where applicable.