

易格斯仓储和物流行业解决方案...

material

material flow.warehousing.logistics.handling...



plastics for longer life® ...12.2013

handling

igus.com.cn/material... igus.eu/materialhandling

适用于物流行业的易格斯产品 ...

室内及室外应用的免维护工程塑料产品

Maintenance-free plastic products in indoor and outdoor applications

- 1 一款几乎适用于所有应用的拖链 One e-chain® for everything **E4.1 系列**
▶ 见页码 16
- 2 电子监控模块 electronic monitoring module **PPDS 装置**
▶ 见页码 14
- 3 导向槽在长行程中的应用 trough for long travels **铝制超级导向槽**
▶ 见页码 17
- 4 自身高度极小的垂直应用 For vertical applications with little system height **liftband**
▶ 见页码 11
- 5 预装配系统 3-10 天交货 Harnessed systems in 3-10 days **装配拖链**
▶ 见页码 23
- 6 用于极高负载的轴承 Bearing for extreme loads **iglidur® Q2**
▶ 见页码 24
- 7 狭窄空间的应用 Rotary movements in minimum space **TwisterBand**
▶ 见页码 12
- 8 免润滑回转环轴承 lubrication-free slewing ring bearing **iglidur® PRT**
▶ 见页码 25
- 9 免维护免润滑关节轴承 Maintenance- and lubrication-free spherical bearings **igubal®** ▶ 见页码 26
- 10 E2/000-模块化导向槽 guiding trough module for E2/000 **guidefast**
▶ 见页码 7
- 11 150 m 行程无耐磨滑条应用 Travels up to 150 m without glide bars **guidelite & E2/000 拖链**
▶ 见页码 6
- 12 高速、高效率应用的轮式拖链 Roller e-chain® for high speeds, energy-efficient **P4 系统**
▶ 见页码 8
- 13 智能拾取输送链 Intelligent transport chain for Pick&Place **pikchain®**
▶ 见页码 28
- 14 无晃动垂直应用 Vertical energy guidance without swinging **guidelok slimline F**
▶ 见页码 10
- 15 安全传输能量、数据和气体 Safe supply of power, data and air **micro flizz®**
▶ 见页码 15

小弯曲半径的电缆 cables with small bending radii
▶ 见页码 20
- 16 用于机器人的三维拖链和可扭转电缆 3D e-chain® and twistable cables for robotics **Triflex® R & CFROBOT**
▶ 见页码 12
- 17 节省 75% 驱动力 Reduce drive power up to 75% **E4.1 轮式拖链**
▶ 见页码 7
- 18 直线导向系统和驱动技术 linear guide systems and drive technology **DryLin®**
▶ 见页码 27
- 19 E2/000标准型拖链 The e-chain® standard **E2/000 系统**
▶ 见页码 18
- 20 多轴机器人关节套件 Multi-axis-joint component kit **roboLink®**
▶ 见页码 29
- 21 替换电缆卷筒，节省电缆 Save cables with alternative to cable drums **e-spool**
▶ 见页码 13

免润滑轴承材料
lubrication-free polymer bearing materials
▶ 见页码 24

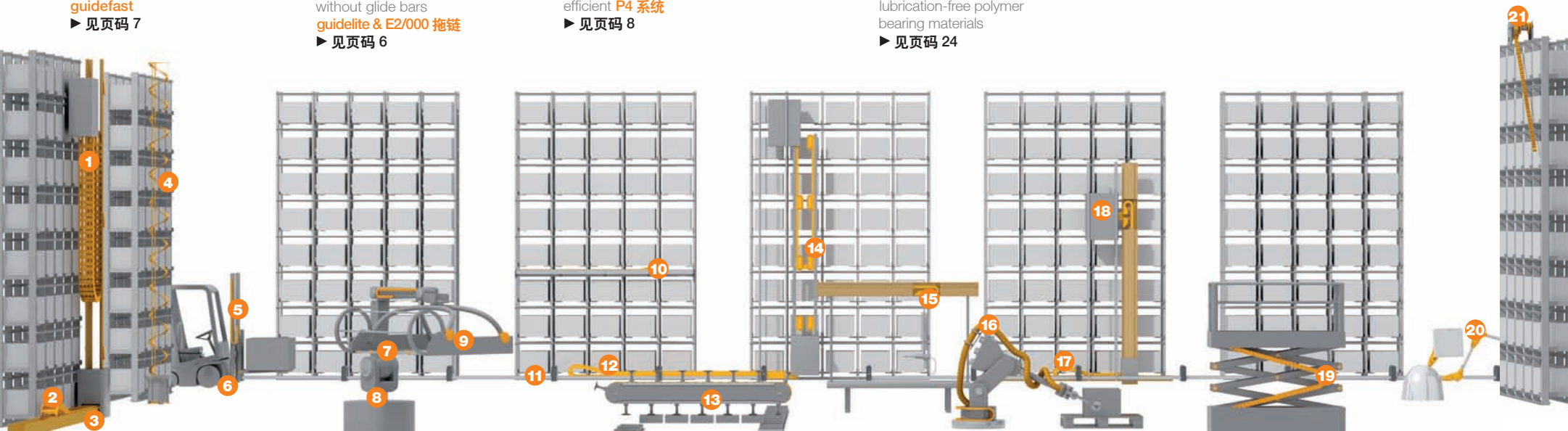

the-chain 用于 150 m 行程 ...

经济又高效 - 可达 150 m 行程

Cost effective and quick – travels up to 150 m

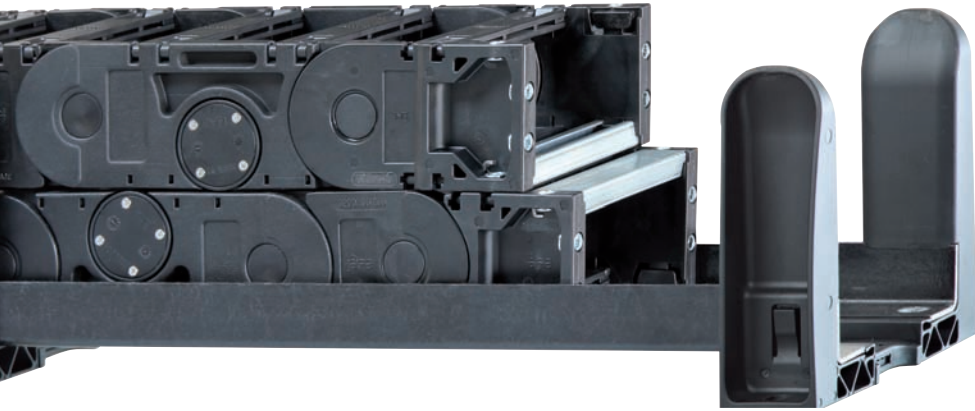

guidelite 及 E2/000 轮式拖链

可用于长达 150 m 的行程，速度小于 4 m/s 的低频运动

- 快速安装，节省时间
- 很轻
- 无耐磨滑条的完整系统
- 可选 10 种内宽
- 可用大量附件的模块化系统
- 常备库存

▶ www.igus.com.cn/guidelite150

guidelite with E2/000 轮式拖链

Travels up to 150 m, applications with low number of cycles speed up to 4 m/s

- Saving time through fast assembly
- Very light
- Complete system can operate without glide bars
- In 10 widths available
- Modular kit with many accessory parts
- Available from stock

▶ www.igus.eu/guidelite150

guidefast - 用于起重机大梁和标准室内起重机

- 相比常规导向槽系统节省 80% 安装时间
- 几乎适用于各种标准起重机
- 除了起重机，还适用于各种侧装应用
- 直接固定在导槽接头上，简化电、气管线安装

▶ www.igus.com.cn/cn/guidefast

guidefast – for crane girders and standard indoor cranes

- Save up to 80% installation time compared to standard trough systems
- Fits virtually any standard crane girder
- Suitable for any side-mounted application - not only on cranes
- Simplified electrification, permanently installed cables can be fixed at the trough brackets

▶ www.igus.eu/eu/guidefast

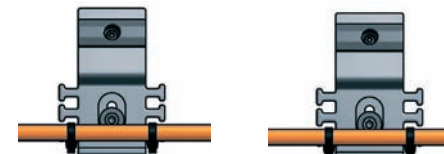

版本 01 -
短接头
short bracket

版本 02 -
长接头
long bracket



the-chain 用于长行程滚动应用 ...

滚动替代滑动 – 最长行程的应用

Rolling instead of gliding – solutions for longest travels

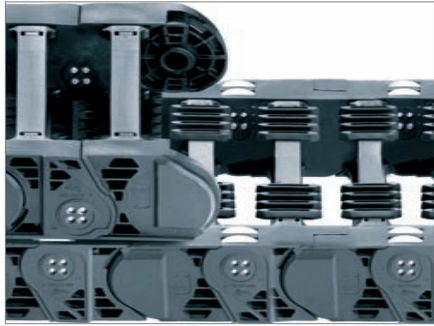

P4 系统 – 轮式拖链

用于长行程应用，速度可达10 m/s，安静运行
● 使用高性能工程塑料滚轮的免维护轮式拖链
▶ www.igus.com.cn/cn/p4

P4 System – Roller chain

For very long travel distances, high speeds up to 10 m/s travel speed, Very quiet running
● Low maintenance roller e-chainsystem® with tribo-optimized plastic rollers
▶ www.igus.eu/eu/p4

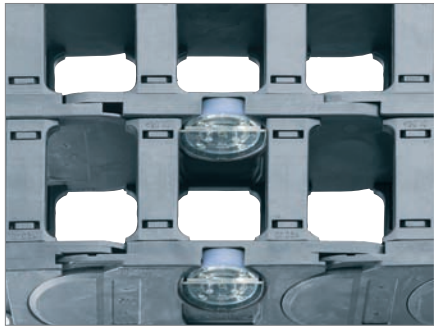

轮式拖链 – 滚动替代滑动

行程可达 800 m，运行速度可达 6 m/s
● 大大降低驱动力
▶ www.igus.com.cn/cn/role

System Roller chain – rolls instead of glides

Travels up to 800 m possible, Speeds up to 6 m/s possible
● Strong reduction of the drive power
▶ www.igus.eu/eu/role

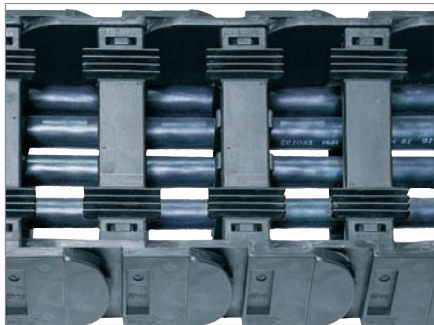

autoglide – 自滑行拖链

行程达 50 m，运行速度 1.5 m/s
● 安装宽度窄，安静运行
▶ www.igus.com.cn/cn/autoglide

autoglide

For travels up to 50 m
For travel speeds up to 1.5 m/s
● Small installation width, silent operation
▶ www.igus.eu/eu/autoglide



E4.1 轮式拖链

大大减少驱动力 – 可用全部 E4 标准套件

- 减少 75% 驱动力
- 滚轮链节与普通链节具有相同的节距和“坡道”
- 滚轮交错平顺运行
- 最高速度：5 m/s
- 具有保护电缆的内部空间
- 可通用 E4.1 大量附件

▶ www.igus.com.cn/cn/E4-1rol

E4.1 轮式拖链

Reduce drive power demands for moving energy chains® - now also with the E4.1 standard toolbox.

- Energy-efficient, reduce drive power by up to 75%
- Same pitch of the roller and normal chain links as well as „ramps“
- Smooth movement of the rolls one upon the other
- Max. speeds: 5 m/s
- Cable-friendly interior separator program
- Immense line of accessories from the E4.1 modular kit

▶ www.igus.eu/eu/E4-1rol

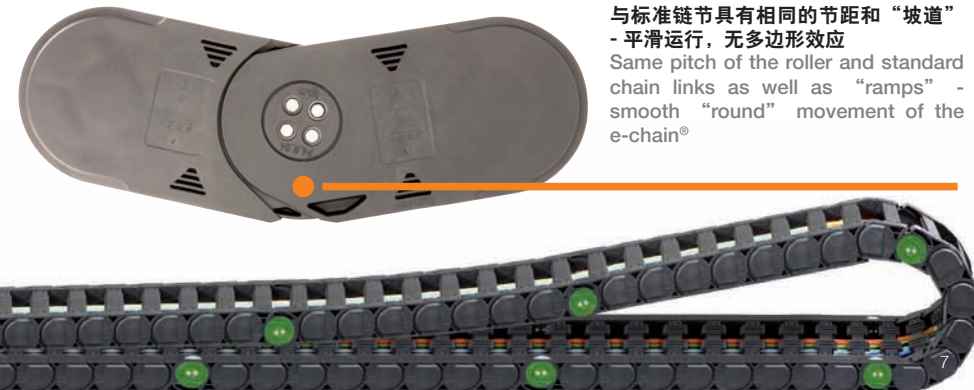

与标准链节具有相同的节距和“坡道” - 平滑运行，无多边形效应

Same pitch of the roller and standard chain links as well as “ramps” - smooth “round” movement of the e-chain®

the-chain 用于垂直应用 ...

无晃动垂直应用

No swinging sideways in vertical energy guidance

guidelok slimline F

高速仓储系统的垂直导向

- 速度可达 7 m/s, 加速度可达 10 m/s²
 - 减少 80% 导向槽
 - 极大地降低成本和减轻重量
 - 用于垂直悬挂长达 50 m 的应用
 - 通过紧固柄使拖链不再发生碰撞, 可靠运行
 - 更快速方便的安装
 - 显著降噪
 - 易于维护
 - 在同一个系统中无障碍传输动力、数据和各种介质
- www.igus.com.cn/cn/gslsl-f

guidelok slimline F

Safe vertical guidance for e-chains® in high-speed storage systems

- Up to 7m/s and 10m/s²
 - Up to 80% less trough required
 - Saves cost and weight
 - For hanging systems up to 50 m
 - No swinging of the chain, high reliability through locking mechanism and guide rails
 - Faster and easier installation
 - Reduced noise
 - Easy access for servicing
 - Energy and data and all kinds of media are safely guided without interrupt in one single system
- www.igus.eu/eu/gslsl-f



www.igus.com.cn/gslsl-f_film
www.igus.eu/gslsl-f_movie

向上传输能量、数据和介质 guide media, energy and data upward

liftband

自身高度极小的垂直应用

- 可用于很高的行程
- 极少磨损, 链节之间几乎不摩擦
- 对电缆弯曲半径的要求不高
- 安静运行, 节省空间

► www.igus.com.cn/liftband

NEW 2012: liftband

High vertical applications, for little system height

- Very high travels are possible
- Less abrasion, as there is almost no friction of the chain links with each other
- Little limitation of cable bending radii
- Silent operation and space saving

► www.igus.eu/liftband



www.igus.com.cn/liftband5
www.igus.eu/liftband5



...旋转运动...

igus® 旋转和螺旋应用
igus® solutions for circular and spiral movements

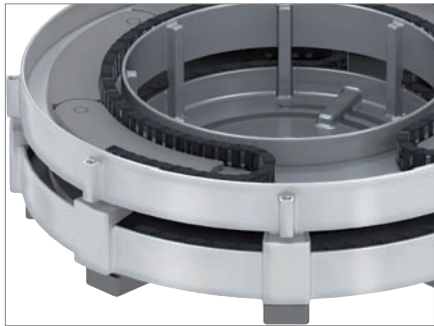

易格斯旋转运动模块化系统
旋转角度达 90° 甚至更大
● 可“无限”扩展
● 用于高负载及有限空间的旋转运动
▶ www.igus.com.cn/rotationsmodul

igus® Rotation modules
Realize circular motions up to 90° and more
● Extendable “indefinitely”
● For rotary motion with high fill weights and limited space
▶ www.igus.eu/rotationmodul



TwisterBand
在狭窄空间旋转可达 7000°
● 4 种尺寸
● 旋转速度可达 360°/s
▶ www.igus.com.cn/cn/TwisterBand

TwisterBand
rotary movement in minimum space up to 7000°
● Available in 4 dimensions
● Rotary speeds up to 360°/s possible
▶ www.igus.eu/eu/TwisterBand

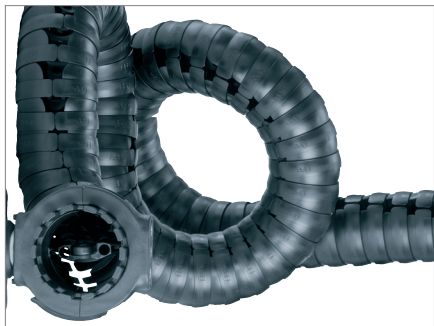

Triflex® R - 三维机器人拖链
专为机器人三维运动而设计
● 每链节可扭转 ± 10°
● 高拉紧度的球槽结构
▶ www.igus.com.cn/cn/TriflexR

Triflex® R 3D e-chain® for robots
Developed for the sophisticated robotic applications
● Approximately +/- 10° torsion per chain link
● High tensile strength through ball-and-socket joint
▶ www.igus.eu/eu/TriflexR



CFROBOT Chainflex® 可扭转电缆每米可扭转 ± 180°, 经过 300000 圈测试
CFROBOT Chainflex® cables for torsion movements: ± 180° at 1 m, 3,000,00 cycles tested

垂直 & 水平...

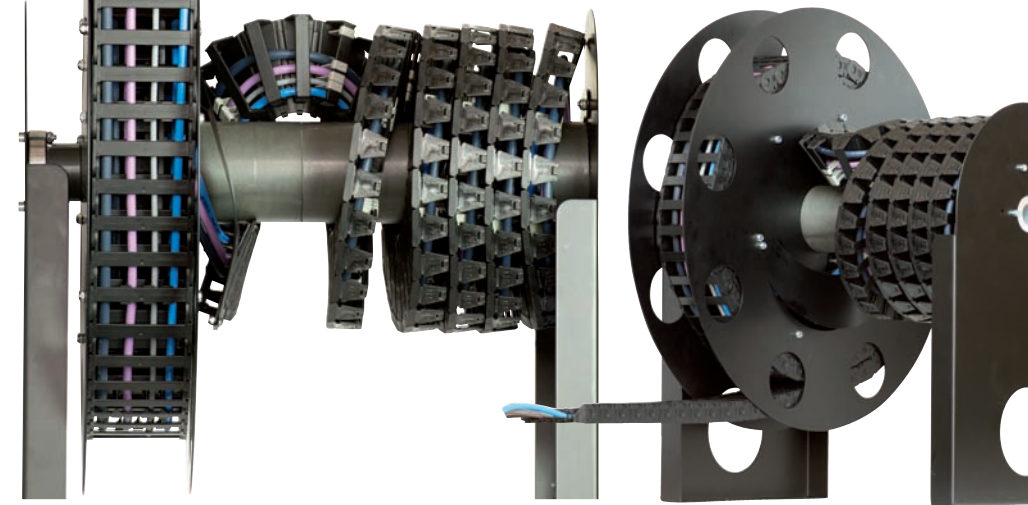

e-spool 模块化套件
替换电缆卷筒：保护电缆，可传输各种管线
● 电缆不承受拉伸力
● 不同直径不同介质管线可在同一个卷筒
● 可实现各方向传输
(水平、垂直、对角线... 该拖链都能实现)
● 节省空间，无链节接口
● 无下端运行拖链，行进路线无阻碍
● 管线直径最大可达 19 mm
▶ www.igus.com.cn/cn/e-spool

e-spool modular kit
The alternative to cable drums – cable-friendly and guides various media safely
● No tensile load of the cables
● Different media and diameters in one drum possible
● Energy supply in all directions is possible (horizontal, vertical, diagonal ... all possible with one chain)
● Space-saving, no “chain junction”
● No lower run is left behind, the paths remain free
● Cable diameter up to 19 mm
▶ www.igus.eu/eu/e-spool



e-spool 用于通风装置
e-spool in winding construction

...更安全...

长行程监控，更安全

Monitoring and more safety for long travels



PPDS basic

以推拉力作为安全测量标准

- 推拉力监控装置现在可用于更多常规的行业
- ▶ www.igus.com.cn/cn/PPDSbasic

PPDS basic

Push/Pull force calculation as safety standard

- Condition Monitoring Systems now available for „standard “ industrial appliances
- ▶ www.igus.eu/eu/PPDSbasic

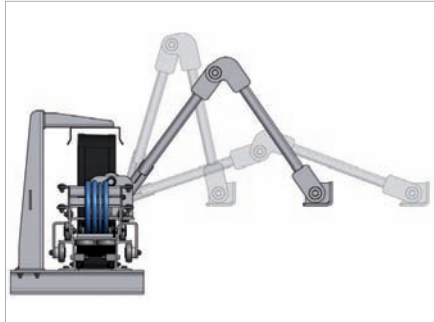

e-roller

为轨道起重机提供动力和数据传输

- 横向偏移补偿
- 可用于长达 800 m 的行程
- ▶ www.igus.com.cn/cn/e-roller

e-roller

power and data supply of rail-bound crane systems

- Compensation of lateral offsets
- For long travels up to 800 m
- ▶ www.igus.eu/eu/e-roller



...安全运行...

一套系统可安全传输能量、数据和介质

One system for safe supply of power, data and air



micro flizz®

一套系统可安全传输能量、数据和气体!

- 紧凑，经济的完整系统用于安全传输能量、介质和气体
- 可替代电刷的免维护系统
- 拖链在单独的槽中滑行，不相互磨损
- 加速度可达 50 m/s²，运行速度可达 6 m/s
- 上下端拖链分开运行，减少摩擦，减少驱动力
- MF10，50 mm 内高
- ▶ www.igus.com.cn/cn/microflizz

micro flizz®

A system for the safe guidance of energy, data and air

- Compact, cost-saving complete system for safe guidance of energy, data and air
- Maintenance-free alternative for power bar
- e-chain® is guided in special slot, no sliding against each other
- Acceleration up to 50 m/s² and operating speed up to 6 m/s
- Separate upper and lower runs on the flizz® e-chain®, hence less friction and reduced power consumption in motion
- MF10 with 50 mm inner width
- ▶ www.igus.eu/eu/microflizz



潜在应用领域:

仓储单元，室内起重机等

Potential application areas: Storage and retrieval units, indoor cranes, etc.

the-chain 大量附件 ...

大量附件，用于起重机和物流设备

Universal kit – e.g. for cranes and material handling

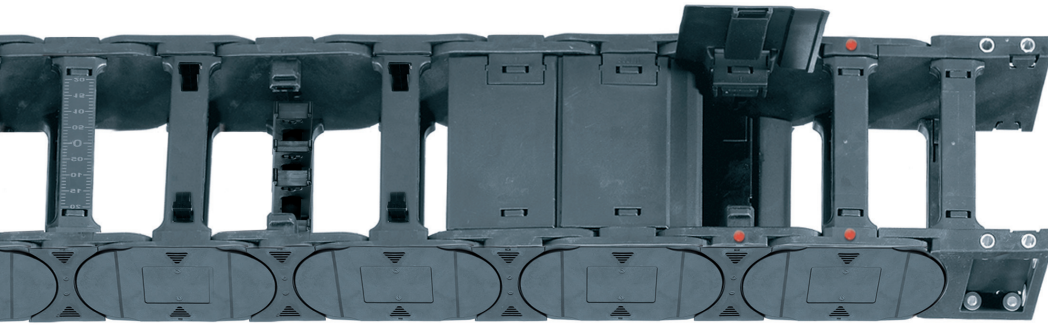

E4.1 拖链 - 标准型

长行程，长架空行程，安装快速，安静运行

- 极佳的侧向稳定性和长行程高推/拉力的倒勾设计
- 理想的侧倒应用
- 坚固的双限位块保证长架空行程
- 可安装降噪垫降低噪音
- 快速安装的内外链节
- 内高: 21-80 mm

▶ www.igus.com.cn/cn/E4.1

E4.1 – the Standard

Long travels, large unsupported lengths, simple installation and quiet operation

- Optimum lateral stability and high push/pull force on long travels due to the undercut design
- Ideal for side-mounted applications
- Large unsupported lengths due to stable, double stop dog
- Noise dampening pads as additional noise-reducing option
- Outer and inner links for fast assembly
- Inner heights: 21-80 mm

▶ www.igus.eu/eu/E4.1



重载型

E4/4 系列- 4040HD 和 5050HD

- 舌榫结构，非常高的坚固性
- 高抗扭性
- 宽滑动面，低磨损

▶ www.igus.com.cn/cn/5050HD

Heavy-Duty

e-chains® E4/4 Series 4040HD and 5050HD

- High stability through “tongue and groove”
- High torsion stability
- Wide gliding surfaces, low wear

▶ www.igus.eu/eu/5050HD

内部分隔 interior separation



接头 Mounting brackets

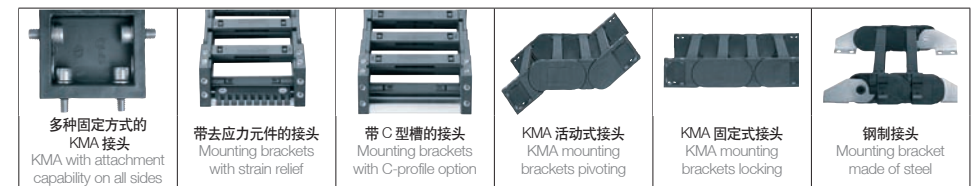

Chainfix 去应力元件 strain relief elements

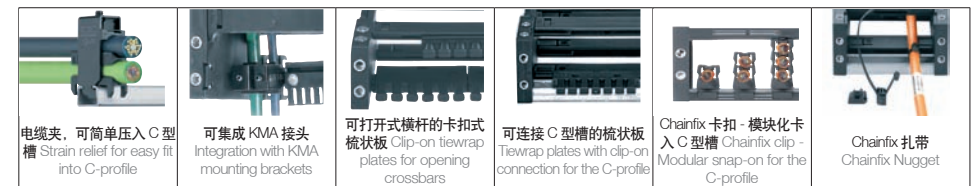

导向槽 Guide troughs



更多解决方案 more solutions

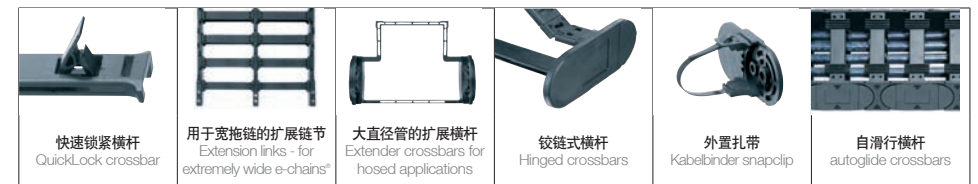

the-chain 高稳定性...

大量附件 – 可用于存储和提取设备

Universal kit – e.g. for storage and retrieval machines

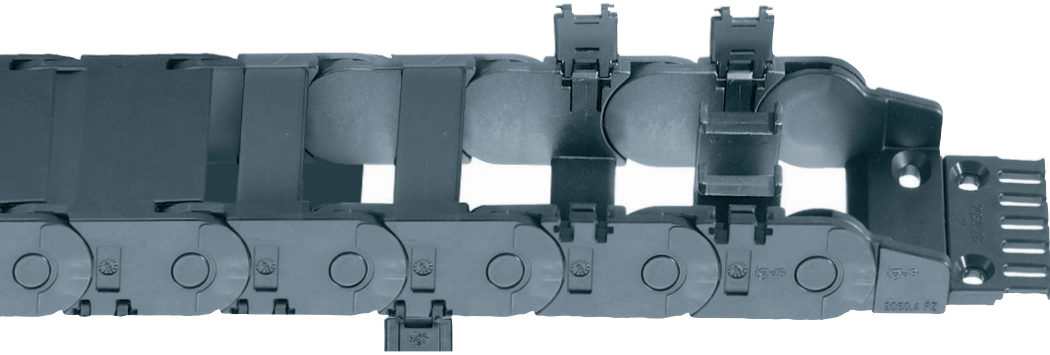

E2/000 系统 – E2 标准型 有拖链，半封闭和全封闭拖管版本

- 使用拖链打开器或螺丝刀从左右两侧打开
- 手动快速闭合 – 无需额外工具
- 材料和设计保证高机械坚固性和长使用寿命
- 两片式设计，快速装配，高效
- 用于长行程滑行和架空运行
- 可用大量附件
- 内高: 21-45 mm

► www.igus.com.cn/cn/E2000

E2/000 系统 – The E2 Standard

Available as e-chain®, half and fully enclosed e-tube, combinable variations

- Open crossbar left or right quickly with screwdriver or the igus® e-chain® opener
- Lightning fast with thumb catch - secure fit without additional locking devices
- Excellent mechanical stability, long life due to design and material
- Very easy to assemble and cost-efficient due to the 2-piece design
- Suitable for long (gliding) travels and unsupported applications
- Many accessories are available
- Inner height: 21-45 mm

► www.igus.eu/eu/E2000

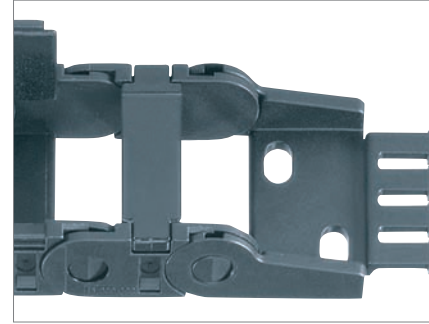

E2 迷你型 – 中小尺寸拖链

短行程和架空运行的理想选择

- 短节距，平滑运行
- 轻质，易于装配，高性价比

► www.igus.com.cn/cn/E2mini

E2 mini – Small and medium sizes

Perfect to use for short travels and unsupported applications

- Small pitch for smooth running
- Lightweight, easy to assemble and cost-efficient

► www.igus.eu/eu/E2mini

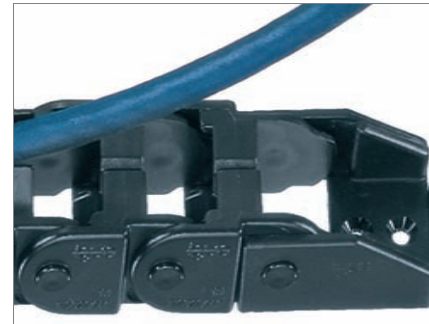

方便型拖链

易于装填，高性价比

- 简单压入电缆
- 小安装空间，一片式设计

► www.igus.com.cn/cn/easychain

Very easy to fill and cost-effective

- Simply push in cables
- One-piece design for small installation space

► www.igus.eu/eu/easychain

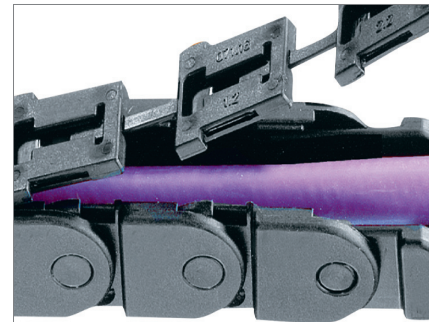

拉链式拖链

快速拉链式打开，获 iF 设计奖

- 快速打开和闭合的拉链式链节设计
- 拉链式链节可在每节连接和拆分

► www.igus.com.cn/cn/zipper

Lightning fast opening and iF design winner

- Zipper-like design for quick opening and closing of lids
- zipper lids can be separated and joined at each chain link

► www.igus.eu/eu/zipper

Chainflex® 拖链专用电缆

1354 种电缆常备库存

More than 1030 cable types from stock

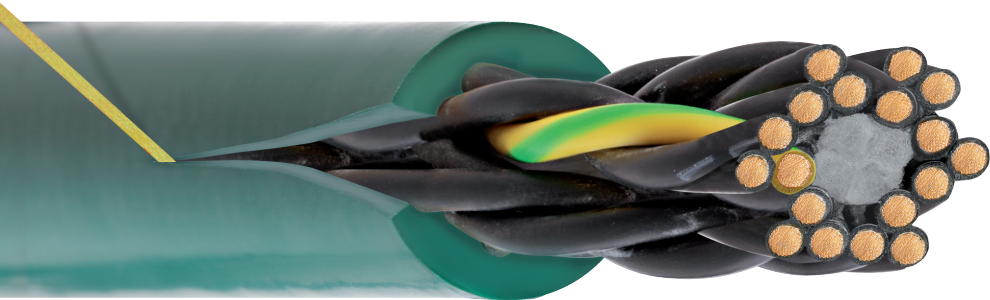

1354 多种 Chainflex® 高柔性电缆专为拖链系统 More than 1030 Chainflex® cables developed especially for the use in e-chainsystems®

系统设计

- 耐磨损 TPE, PUR 和 PVC 耐油外护套
- 无卤素, 阻燃材料
- 符合多种标准: UL, CSA, CE, DESINA, CEI
- 最小弯曲半径 4 x d

▶ www.igus.com.cn/Chainflex

- Wear resistant TPE, PUR and oil-resistant PVC outer jackets
- Halogen-free and/or flame-retardant materials
- Different certificates: UL, CSA, CE, DESINA, CEI
- Smallest radii up to 4 x d

▶ www.Chainflex.eu



优质电缆的 7 大要素

7 basic rules of flexible x cables



Chainflex® 经久耐用... 适用于拖链

Chainflex® 高柔性电缆避免拖链应用中的电缆失效。

1. 高抗拉中间加强芯
2. 绞线导体
3. 芯线绝缘层
4. 芯线绞合
5. 甲冑式高压内护套
6. 最佳编织角度的屏蔽层
7. 挤压成型耐磨损外护套

Chainflex® lasts... in the energy chain®

Chainflex® cables prevent cable downtimes in energy chain® applications.

1. Center element for high tensile stresses
2. Optimized copper litz wire
3. Core insulation
4. Braiding in bundles
5. Gusset-filling extruded inner jacket
6. Total shield with optimized shield braiding
7. Pressure extruded, abrasion-resistant outer jacket

缆...

用于物流行业的 Chainflex® 高柔性电缆
Chainflex® cables for material handling

CF111.D / CF113.D – PUR 数据电缆 PUR data cable



用于高负载的测量系统电缆, PUR 外护套, 带屏蔽, 耐油和冷却剂, 耐划痕, 阻燃, 耐水解和微生物, 最小弯曲半径 10 x d。 measuring system cable for high load requirements, PUR outer jacket, shielded, resistant to oils and coolants, notch proof, flame-retardant, hydrolysis-resistant and microbe-resistant, minimum bending radius up to 10 x d

CF270.UL.D / CF27.D – PUR 伺服电缆 PUR servo cable



用于高负载的伺服电缆, PUR 外护套, 耐油和冷却剂, 带屏蔽, 耐划痕, 阻燃, 耐水解和微生物, 不含 PVC 和卤素, 最小弯曲半径 7.5 x d。 servo cable for high load requirements, PUR outer jacket, shielded, resistant to oils and coolants, notch proof, flame-retardant, hydrolysis-resistant and microbe-resistant, PVC-free/halogen-free, minimum bending radius up to 7.5 x d

CF5 / CF6 – PVC 控制电缆 PVC control cable



用于高负载的控制电缆, PVC 外护套, 耐油, 阻燃, 最小弯曲半径 6.8 x d, 带 CFRIP 长距离快速剥线绳。 Control cable for high load requirements, PVC outer jacket, oil-resistant, flame-retardant, minimum bending radius up to 6,8 x d, with new CFRIP tear strip for quick and effective jacket stripping of long stripping lengths

CFBUS.001 / CFBUS.045 – TPE 总线电缆 TPE bus cables



用于极大负载的 Profibus 和 Ethernet/CAT5/GigE 电缆, TPE 外护套, 带屏蔽, 耐油和生物油, 阻燃, 最小弯曲半径 10 x d profibus and ethernet/CAT5/GigE cable for maximum load requirements, TPE outer jacket, shielded, oil- and biooil-resistant, flame-retardant, minimum bending radius up to 10 x d

CFSPECIAL.182 用于逐渐增加的拉伸力 for increased tensile stress



Profibus-/Ethernet-电缆用于 50 m 悬挂应用拉伸力高达 500 N。 Profibus-/Ethernet cables for hanging applications up to 50 m. For increased tensile load up to 500 N.

装配电缆...

装配电缆和能量传输系统

Harnessed cables and energy supply systems



装配电缆 – 24-48 小时或当天交货

易格斯提供满足 20 个制造商要求的 2240 种型号的装配电缆。专业装配 100% 经测试。

- 伺服、动力及信号/编码器电缆
- 无切割费用，无最小起订量，无额外费用
- 根据客户需要定制长度
- 最小弯曲半径 7.5 x d
- 降低库存成本，提高现金流

► www.igus.com.cn/readycable

readycable® – in 24-48h or today

igus® offers more than 2240 harnessed cables for drive systems according to 20 different manufacturers. Professionally manufactured, 100 % tested.

- Servo, Power and Signal-/encoder cables
- No cutting costs, no minimum order quantity, no costs for packaging
- Cable length according to customer requirements
- Smallest bending radii from 7,5 x d
- Reduce storage cost and increase cashflow

► www.igus.eu/readycable

QuickPin 2.0 ePLAN® electric8



QuickPin 2.0 – 电缆接头在线配置器

► www.igus.com.cn/quickpin
connector-cable configurator
► www.igus.eu/quickpin



Intercontec SpeedTec 包装服务 (1 个起)，或直接根据客户要求装配 Servicepacks (from 1 piece), or directly harnessed according to customer specifications



也有一体成型-根据您的设计 Also as molded version – with your individual design



装配拖链...

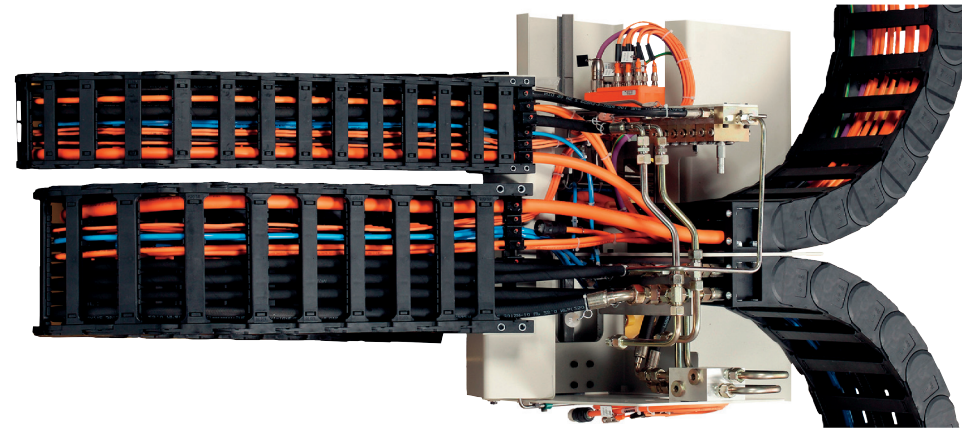

装配拖链 3-10 天发货

全球 11 家装配工厂每周装配 700 台系统。易格斯装配拖链节省您的装配时间，提高现金流。

- 消除电缆拖链和接头的库存成本
- 周转期减少一半
- 灵活的订单管理
- 减少 75% 供应商的订单量
- 最小化停机时间
- 根据应用的系统提供质量保障

► www.igus.com.cn/readychain

readychain® – Ready-to-fit assembled systems in 3-10 days

700 systems per week in 11 readychain® companies around the world – assembly-optimized and raise your cash-flow

- Reduce your storage costs for cables, e-chains® and connectors to zero
- Shorten turnaround times by half
- Flexible response to order fluctuations
- Reduce the number of subcontractors and related orders by 75%
- Minimize your machine downtimes
- System guarantee – for your application

► www.readychain.eu

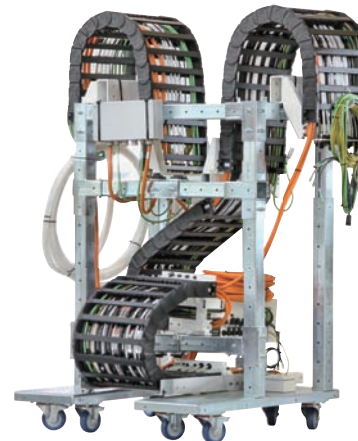

装配电缆支架

减少样机 80% 设计时间。即装即用装配拖链系统。

readychain® transport rack

Reduces process costs by up to 80% during prototyping. Assembly transport rack for ready-to-install energy supply systems.

易格斯 dry-tech® 轴承...

易格斯免维护轴承

Maintenance-free bearings from igus®



igidur® 轴承

高性能工程塑料免润滑免维护轴承，可预测使用寿命

- 40 种不同材料
 - 耐腐蚀
 - 耐脏污
 - 高吸振性
 - 低摩擦系数
 - 高耐磨损
- ▶ www.igus.com.cn/igidur

igidur® bearings

Maintenance- and lubrication-free Bearings, made from high-tec polymers – Lifetime predictable

- 40 different materials
 - Corrosion-resistance
 - High dirt resistance
 - High vibration dampening
 - Low coefficient of friction
 - High wear-resistance
- ▶ www.igus.eu/igidur



igidur® G 全能型

用于中高负载的全能型轴承

▶ www.igus.com.cn/cn/g

igidur® G - the Allrounder

Bearing for universal use with medium to high loads

▶ www.igus.eu/eu/g



igidur® Q2 极高负载

极高负载旋转应用的免润滑轴承解决方案

▶ www.igus.com.cn/cn/q2

igidur® Q2 - The high-load bearing

Bearing solution for heavy-duty pivoting applications under extreme conditions.

▶ www.igus.eu/eu/q2

100% 免润滑 ...

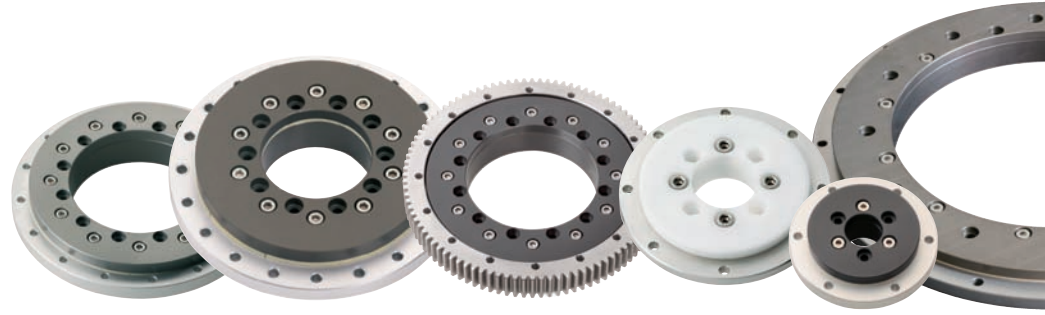

igidur® PRT - 回转环轴承

igidur® PRT 经济实惠，免维护，由易格斯优化工程塑料滑动单元组成的回转环平台。

- 即装即用
 - 坚固，耐腐蚀，适用于高载荷
 - 用于多变的环境
 - 免润滑，免维护
 - 用于中低滑动速度
 - 也有带齿形外圈版本
- ▶ www.igus.com.cn/cn/prt

igidur® PRT - Slewing Ring Bearing

igidur® PRT is an economical, maintenance-free slewing ring table with tribo-optimized iglidur® polymer sliding parts

- Ready to install
 - Robust, corrosion-resistant bearing for high loads
 - For the use in changing environments
 - Maintenance- and lubrication-free
 - For low to medium gliding speeds
 - Also with toothed outer ring
- ▶ www.igus.eu/eu/prt

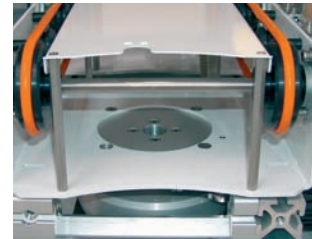

处理及运输电子产品

Handling- and transportsystem for semicon ductor-transport/-box



用于机床控制面板的回转环轴承，即装即用 Ready to install slewing ring bearing at a machine control panel

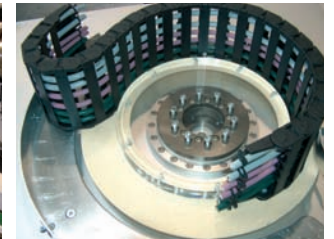

使用 iglidur® PRT 和 易格斯 RBR 拖链的旋转运动 Circular movement with iglidur® PRT and igus® RBR

无边缘负载...

免维护 igubal® 基座和法兰轴承

Maintenance-free igubal® pillow block and flange bearings



igubal® 基座轴承

易于安装的轴承

- 补偿误差
- 在各种负载下具有长使用寿命

▶ www.igus.com.cn/pillowblocks

igubal® pillow block bearings

very easy-to-mount bearing elements

- Compensation of errors
- High fatigue strength in varying loads

▶ www.igus.eu/pillowblocks



igubal® 法兰轴承

用于轴端和轴承套

- 轻质，小安装空间
- 带 2 或 4 个安装孔

▶ www.igus.com.cn/igubal-flange

igubal® flange bearing

for the bearing of shaft ends or shaft bushings

- Low weight, for small installation space
- With 2 and 4 mounting holes

▶ www.igus.com.cn/igubal-flange



食品行业传送系统 Conveyor system for the food industry



耐脏污: igubal® 基座轴承用于石材加工 Resistant to dirt: igubal® pillow block bearings in stone processing



高性价比的 igubal® 法兰轴承用于旋转铲 Cost-effective igubal® flange bearings in a rotary sorter

...直线导轨...

DryLin® 直线导向技术: 滚动替代滑动

DryLin® linear technology: Rolls instead of gliding

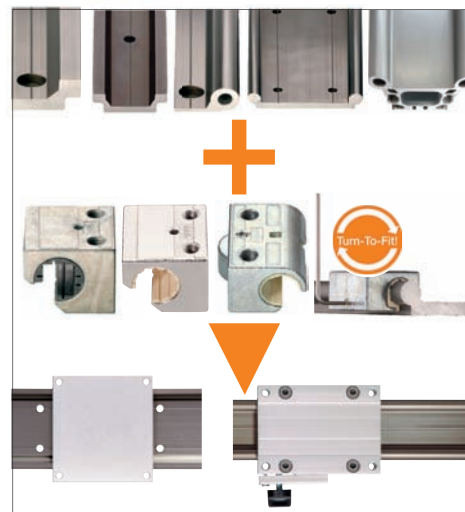

DryLin® W 模块化套件

5 种材料常备库存

- 导轨: 方形/圆形, 单轨/双轨
- 滑块: 带角度/圆形/灵巧型
- 滑动平台: 长型/短型/预装配

▶ www.igus.com.cn/cn/DryLinW

DryLin® W modular linear kit

5 sizes available from stock

- Rails: square/round, single/double shafts
- Linear housings: angular/round/flexible
- Guide carriages: short/long/ready to fit

▶ www.igus.eu/eu/DryLinW



存储滑动单元自动存储/检索系统 Storage-slide unit for an automatic storage/retrieval system

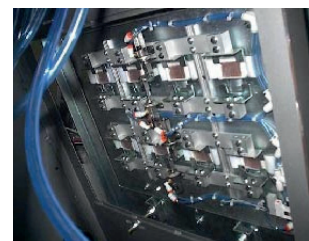

自动吸塑封口机 Automatic product feed to a blister sealing machine

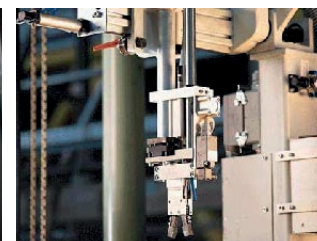

工业机器人卸载装置 Unloading robot in industry

...智能输送链...

工程塑料自动化: 智能拾取应用输送链和低成本机器人

Polymer automation: transport chain for intelligent pick & place applications and low-cost robotics



模块化拾取智能输送链: pikchain® PC2

100% 模块化系统。pikchain® PC2 新型的循环链采用标准化 E4.1 系统为基础的模块化系统。简化的安装形式, 使 pikchain® 的模块化配置具有更高性能。侧板滑行元件采用 iglidur® J 材料, 因此使用寿命大大提升。PC2 的元件都来自于拖链产品, 基本常备库存。

- 模块化拾取应用
 - 行程可达 30 m, 速度可达 3 m/s
 - 可水平、垂直或 90°侧装
 - 最大负载每节 2 kg
 - 执行器安装板与集成螺纹衬套
 - 持续可调的 c-chain® 和传送带
- www.igus.com.cn/pikchain

The modular Pick&Place solution from the modular kit that adjusts itself to the application: pikchain® PC2

100% modular kit. The new pikchain® PC2 is based on components from the E4.1 igus® energy chain® modular kit. This simplifies the installation, enables a modular configuration of the pikchain® and ultimately increases the profitability. The side-plates made from the E4.1 modular kit have integrated, abrasion-optimized gliding elements made of iglidur® J. The service life is thereby considerably increased. As the PC2 components come from the chain product range, delivery from stock is practically possible.

- Pick&Place from the modular kit
- Travels up to 30 m and speeds up to 3 m/s
- Can be installed vertically, horizontally and side-mounted 90°
- Max. load per chain link 2 kg
- Actuator mounting plate with integrated threaded bushings
- Continuous adjustment potentials of the c-chain® and drive belt guidance

► www.igus.eu/pikchain

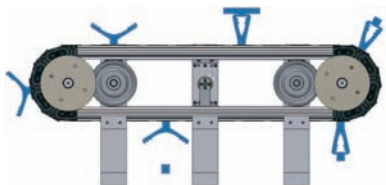

例如: pikchain® 智能拾取应用 Example: Pick and place of a work piece with pikchain®

...多轴机器人关节...

roboLink® 多轴机器人关节: 多套件组合让机器人关节运动自如

轻巧: 元件由工程塑料制成

- 免润滑
- 长使用寿命
- 低价格

紧凑: 多轴关节可实现两个维度上的运动

- 轴向旋转和摆动旋转
- 可通过设计调整臂长

自如: 自由选择驱动系统

- 装配即可使用
- 可连接 4 个轴 (4 DOF)
- 通过易格斯提供牵引绳及步进电机实现驱动
- 易于更换的驱动及控制系统

► www.igus.com.cn/roboLink

roboLink® multi-axis joint: Components kit to make movable robotic systems

LIGHT: Joint made of tribo-polymers

- Lubrication-free
- Low-priced
- Long-life

COMPACT: Multiple-axis joint with 2 DOF

- Pivoting AND rotating
- Freely configurable „arm length “ through modular design

FREE: Freely selectable drive systems

- Connect AND start
- Compact drive unit for a 4-axis articulated arm (4 DOF)
- Drive via sinews (and/or ropes) and stepper motors by igus®
- Alternative drive/control systems easily possible

► www.igus.eu/roboLink



igus® 实验室和测试...

2,750 m² 的实验室 ... 每年 8000 项测试 ... 1000 项拖链和电缆使用
2,750 m² lab ... 8,000 tests per year ... 1,000 datasets on service life

寿命测试仪实验

of chains and cables created every year

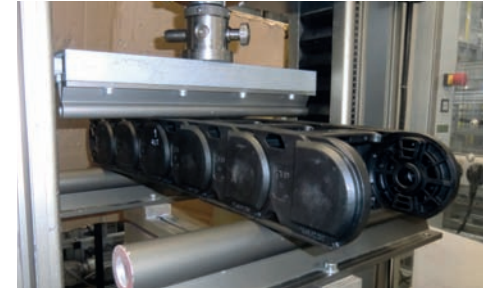

破坏性测试: 计算最大架空长度
break test: calculation of max. unsupported length



介质测试: 化学介质中的耐久度测试
Media test: Test of durability of chemical interferences in motion



质量保证: 批次测试以保证质量水平
Quality Assurance: Continuous batch testing to ensure the quality level

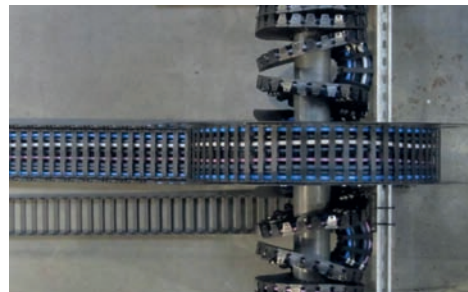

特殊设计用于特殊解决方案
Special design for special solutions

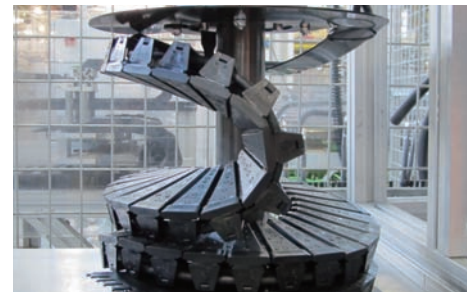

螺旋运动测试: 极小的弯曲半径运行
Rotation tests: ambitious chain applications with small radii



低温测试: 拖链和电缆在 -40°C 下运行
Frost test of cables and e-chains® at -40°C

igus® 服务 & 在线工具...

装配服务, 在线工具, 易格斯服务... 24小时发货!

Assembly service, online tools, igus® service... from stock in 24h!



易格斯准确的安装服务, 避免停机时间和额外费用
- 易格斯装配拖链质保承诺

- 来自同一供应商的产品和服务 - 减少物流烦恼
- 易格斯系统质保承诺

▶ www.igus.com.cn/assemblyservice



Get an accurate assembly and avoid machine downtimes and extra costs – with the igus® e-chainsystem® assembly service

- Products and services from one source – less logistical hassle for you
- igus® system guarantee

▶ www.igus.eu/assemblyservice



易格斯样本

igus® catalog product range
在线申请易格斯样本: www.igus.com.cn/catalog
Excerpt of catalog on next pages, order igus® catalogs online www.igus.eu/catalog



常备库存. 24 小时或当天发货

Delivery from stock. 24h or on request.
易格斯产品 24 小时发货, 可根据您的要求安排物流。The goods leave igus® within 24 hrs. On request we can deliver via express or special delivery.



在线商铺

访问 www.igus.com.cn. 您能找到易格斯完整的产品范围。See www.igus.eu. There you can find our whole product range. Order around the clock.



订购时间 Ordering times

周一到周六 8:00 - 20:00
Monday to Saturday 7:00 am - 8:00 pm



还有任何问题?

You have questions?
还有任何问题, 请来电或使用在线工具, www.igus.com.cn。For questions and more information call us or use our onlinetools on www.igus.eu.



服务热线 Hotline

电话: 021 5130 3100
传真: 021 5130 3200

用于物流行业的在线工具

A selection of important Online-Tools for material handling



QuickChain.100

拖链计算和配置器
Calculation & layout of e-chains®

▶ www.igus.com.cn/eks-expert
▶ www.igus.eu/ecs-expert



QuickChain.13

13 m 行程以下的拖链查找
product finder up to 13 m

▶ www.igus.com.cn/quickchain13
▶ www.igus.eu/quickchain13



QuickLife

拖链使用寿命计算器
Service life of e-chains®

▶ www.igus.com.cn/eks-lifetime
▶ www.igus.eu/ecs-lifetime



QuickFind

拖链产品查找
Product finder

▶ www.igus.com.cn/eks-finder
▶ www.igus.eu/ecs-finder



QuickFill

拖链填充专家系统
e-chain® filling expert

▶ www.igus.com.cn/ia-configurator
▶ www.igus.eu/filling-configurator



QuickCad circular

旋转运动拖链配置
e-chains® with circular motion

▶ www.igus.com.cn/rbr-configurator
▶ www.igus.eu/rbr-configurator



QuickCad spiral

圆周运动拖链配置器
spiral e-chains®

▶ www.igus.com.cn/twisterconfigurator
▶ www.igus.eu/twisterconfigurator



QuickCable

电缆查找器
Product finder cables

▶ www.igus.com.cn/quickcable
▶ www.igus.eu/quickcable



QuickLife

使用寿命计算器
Service life calculation

▶ www.igus.com.cn/cf-lifetime
▶ www.igus.eu/cf-lifetime



QuickPin 2.0

电缆接头配置器
Connector-cable configurator

▶ www.igus.com.cn/quickpin
▶ www.igus.eu/quickpin



QuickBearing

iglidur® 滑动轴承查找器
iglidur® product finder

▶ www.igus.com.cn/iglidur-productfinder
▶ www.igus.eu/iglidur-productfinder



QuickBearing.custom

棒料查找器
Product finder for stock bars

▶ www.igus.com.cn/stockbar-produktfinder
▶ www.igus.eu/stockbar-productfinder



QuickLin

DryLin® 系统设计
DryLin® system design

▶ www.igus.com.cn/DryLin-expert
▶ www.igus.eu/DryLin-expert



QuickLin

驱动产品查找器 product finder drive technology

▶ www.igus.com.cn/sht-productfinder
▶ www.igus.eu/sht-productfinder



QuickRobolink

机器人关节配置器 Multi-axis-joint configurator

▶ www.igus.com.cn/roboLink-configurator
▶ www.igus.eu/roboLink-configurator

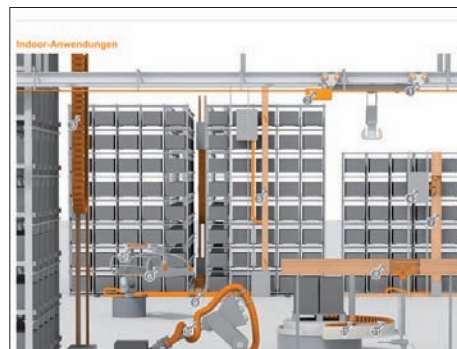

物流专业网站

用于物流的更多的信息、应用和视频和产品细节, 请访问

▶ www.igus.com.cn/material

Special website for material handling

You can find information, applications, videos and product details for material handling on

▶ www.igus.eu/material

igus® 应用案例 ...

易格斯产品在物流行业的应用案例 - 在线查看更多案例: www.igus.com.cn/material-applications

Examples for successful applications with igus® products – more online: www.igus.eu/materialhandling-applications



易格斯 guidelok slimline F 用于安全垂直导向 (28 m 行程) With cost-effective igus® guidelok slimline “F” safe vertical guiding (here: 28 m)



大型龙门起重机应用
Existing applications could be enhanced once again



特殊耐磨损材料
Abrasion-free due to special materials



DryLin® W 用于具有表面特殊要求的输送链
Chain for sensitive surfaces with DryLin® W linear guide system



长行程架空应用: 伸展臂起重机和地面输送链
Long unsupported travels: perfect for telescope cranes or floor conveyors



P4.56 拖链: 长达 120 m 的户外应用
P4.56: igus® outdoor test set up - travel length 120 m



DryLin® W 用于高架仓储设备 - 提升轴
DryLin® W in high-rack facilities – Application: Lift axis

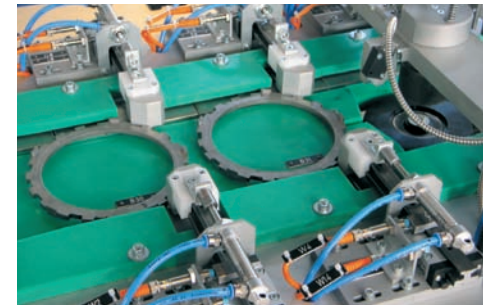

DryLin® 用于汽车行业涡流探伤检测
DryLin® test station for the eddy-current crack test of components for the automobile industry



中等尺寸的拖链用于高架仓储设备
e.chains® in medium size in storage and retrieval machines



Chainflex® 电缆用于户外应用
Perfect for outdoor applications: Chainflex®



igidur® 用于高负载
igidur® – also for high loads



耐磨损、不生锈, 长使用寿命的 igubal® 用于输送带
No abrasion, no corrosion, long service life with igubal®

易格斯全球...

易格斯分公司	10 加拿大 igus® Office Canada Suite 100-180 Bass Pro Mills Dr Vaughan, ON L4K 5W4 Phone +1 905 7608448 Fax +1 905 7608688 webmaster@igus.com	20 爱沙尼亚 igus® OÜ Lõotsa 4A Tallinn 11415 Phone +372 667 5600 Fax +372 667 5601 info@igus.ee	28 爱尔兰 igus® Ireland Caswell Rd Northampton NN4 7PW Phone +44-1604 677240 Fax +44-1604 677242 sales@igus.ie	38 墨西哥 igus® México S.de R.L. de CV. Boulevard Aeropuerto Miguel Alemán 160 Int. 135 Col. Corredor Industrial Toluca Lerma Lerma, Estado de Mexico C.P. 52004 Phone +52 728284 3165 Fax +52 728284 3187 fmarquez@igus.com
易格斯经销商	11 智利 Vendortec Avda. Los Pajaritos 3195, Oficina 1410 Edificio Centro Maipú Maipú - Santiago Phone +56 22 710 58 25 +56 23 245 02 00 ventas@vendortec.cl	21 芬兰 igus® Finland OY Fiskarsinkatu 3 20750 Turku PL 9, 20101 Turku Phone +358 20 7499499 Fax +358 20 7499456 info@oem.fi	29 以色列 Conlog LTD P.O. Box 3265 17 Hamelassim Str. Industrial Zone Kiryat Arie Patach-Tikva 49130 Phone +972 3 9269595 Fax +972 3 9233667 conlog@conlog.co.il	40 中东地区 JISigis Middle East FZE FPO7, Jebel Ali Free Zone PO Box- 17483 Dubai, United Arab Emirates Phone +971 4222 1185 Fax +971 4222 1186 info@jisigis.com
1 德国 igus® GmbH Spicher Str. 1a 51147 Köln P.O. Box 90 61 23 51127 Köln Phone 02203 9649-0 Fax 02203 9649-222 info@igus.de, www.igus.de	12 中国 易格斯上海滚链系统有限公司 上海市奉贤区环城北路50号 201401 电话 021-8036 6999 传真 021-8036 6116 cnmaster@igus.net	22 法国 igus® SARL 49, avenue des Pépinières Parc Médicis 94260 Fresnes Phone +33 1 49840404 Fax +33 1 49840394 info@igus.fr	30 意大利 igus® S.r.l. Via delle Rovedine, 4 23899 Robbiate (LC) Phone +39 0395906.1 Fax +39 0395906.222 igusitalia@igus.it	41 缅甸 Sea Lion Co. Ltd. 181 Bo Myat Tun St Botataung Yangon 11161 Myanmar Phone +85 1 29 97 97 Fax +95 1 20 27 51 zaw.m.hant@sealionmyanmar.com
2 阿根廷 Borintech SRL Av. Elcano 4971 14270IH Buenos Aires Phone +5411 4566 1000 Fax +5411 4556 1000 igus@borintech.com	13 中国 易格斯上海滚链系统有限公司 上海市奉贤区环城北路50号 201401 电话 021-8036 6999 传真 021-8036 6116 cnmaster@igus.net	23 希腊 igus® SARL 49, avenue des Pépinières Parc Médicis 94260 Fresnes Phone +33 1 49840404 Fax +33 1 49840394 info@igus.fr	31 日本 igus® k.k. Arcacentral 15F, 1-2-1 Kinshi, Sumida-ku Tokyo JAPAN Zip 130-0013 Phone +81 358 192030 Fax +81 358 192055 info@igus.co.jp	42 荷兰 igus® B.V. Sierrenbergweg 9 3769 BS Soesterberg Phone +31 346 353932 Fax +31 346 353849 info@igus.nl
3 澳大利亚 Treotham Automation Pty. Ltd. 14 Sydenham Road Brookvale NSW 2100 Phone +61 2 9907-1788 Fax +61 2 9907-1778 info@treotham.com.au	13 哥伦比亚 Productos igus® SAS Calle 33A, #21-09 Bogotá Phone +57 1 561 2959 ext. 113 igus@igus.com.co	23 希腊 J. & E. Papadopoulos S.A. 12 Polidefkous str Piraeus, 165 40 Phone +30 210 4113133 Bogotá Phone +30 210 4116781 sales@papadopoulos-sa.com	31 日本 igus® k.k. Arcacentral 15F, 1-2-1 Kinshi, Sumida-ku Tokyo JAPAN Zip 130-0013 Phone +81 358 192030 Fax +81 358 192055 info@igus.co.jp	42 荷兰 igus® B.V. Sierrenbergweg 9 3769 BS Soesterberg Phone +31 346 353932 Fax +31 346 353849 info@igus.nl
4 奥地利 igus® polymer Innovationen GmbH Photo-Play-Straße 1 4860 Lenzing Phone +43 7662 57763 Fax +43 7662 57751 igus-austria@igus.de	14 哥斯达黎加 Enesa Equipos Neumaticos S.A. Del Colegio Marina 100 este, 200 sur, 25 este Urbanizacion Ciriuelas Alajuela, Costa Rica Phone +506 2440-2393 Fax +506 2440-2393 equiposneumaticos@enesa.net	23 希腊 Chrismotor s.a. 71, Sp. Patsi str. 118 55 Athens Phone +30 210 34 25574 Fax +30 210 3425595 info@chrismotor.gr	32 肯尼亚 Mantrad Ltd. Sterling House, 1st. Floor Moi Avenue, Mombasa Phone +254 722 706 830 Fax +254 720 765 566 info@mantrad.co.ke	42 荷兰 igus® B.V. Sierrenbergweg 9 3769 BS Soesterberg Phone +31 346 353932 Fax +31 346 353849 info@igus.nl
5 白俄罗斯 SOOO Hennlich Bryuzova Street, 4/5, office 1012 220073 Minsk Republik Belarus Phone +375 17 258 8828 Fax +375 17 373 3926 info@hennlich.by	15 克罗地亚 Hennlich, Industrijska d.o.o. Stupničkoobraška 17 Stupnički Obrež 10255 Gornji Stupnik Phone +385 1 3874334 Fax +385 1 3874336 hennlich@hennlich.hr	23 希腊 Chrismotor s.a. 71, Sp. Patsi str. 118 55 Athens Phone +30 210 34 25574 Fax +30 210 3425595 info@chrismotor.gr	33 拉脱维亚 Techvitas SIA Daugavas iela 38-3 M ū r p, LV-2167 Phone +372 667 5600 Fax +372 667 5601 l_igus.Lettland_G@igus.de	42 荷兰 igus® B.V. Sierrenbergweg 9 3769 BS Soesterberg Phone +31 346 353932 Fax +31 346 353849 info@igus.nl
6 比利时/卢森堡 igus® B.V.B.A. Jagersdreef 4A 2900 Schoten Phone +32 3 330 13 60 Fax +32 3 313 79 19 info@igus.be	15 克罗地亚 Hennlich, Industrijska d.o.o. Stupničkoobraška 17 Stupnički Obrež 10255 Gornji Stupnik Phone +385 1 3874334 Fax +385 1 3874336 hennlich@hennlich.hr	23 希腊 Chrismotor s.a. 71, Sp. Patsi str. 118 55 Athens Phone +30 210 34 25574 Fax +30 210 3425595 info@chrismotor.gr	33 拉脱维亚 Techvitas SIA Daugavas iela 38-3 M ū r p, LV-2167 Phone +372 667 5600 Fax +372 667 5601 l_igus.Lettland_G@igus.de	42 荷兰 igus® B.V. Sierrenbergweg 9 3769 BS Soesterberg Phone +31 346 353932 Fax +31 346 353849 info@igus.nl
7 波斯尼亚+黑塞哥维纳 Hennlich d.o.o. Tvornička 3 (Energoinvest-zgrada C&C) BH+71210 Iliđaža - Sarajevo Phone +387 33 451 439 Fax +387 33 451 439 info@hennlich.ba	16 捷克 HENNLICH s.r.o. Ceskolpíská 9 412 01 Litom ě rice Phone e-chains +420 416 711332 Phone Plain bearings +420 416 711339 Fax +420 416 711999 lin-tech@hennlich.cz	25 匈牙利 igus® Hungária Kft. Ipari Park u.10, 1044 Budapest Phone +36 1 3066486 Fax +36 1 4310374 info@igus.hu	33 拉脱维亚 Techvitas SIA Daugavas iela 38-3 M ū r p, LV-2167 Phone +372 667 5600 Fax +372 667 5601 l_igus.Lettland_G@igus.de	42 荷兰 igus® B.V. Sierrenbergweg 9 3769 BS Soesterberg Phone +31 346 353932 Fax +31 346 353849 info@igus.nl
8 巴西 igus® do Brasil Ltda. Rua Antônio Christl, nº 611 Parque Industrial III – FAZGRAN Jundiá – CEP 13213-183 – SP Phone +55 11 3531-4487 Fax +55 11 3531-4488 vendas@igus.com.br	17 丹麦 igus® ApS Lysholt Alle 8 DK-7100 Vejle Phone +45 86 603373 Fax +45 86 603273 info@igus.dk	25 匈牙利 Tech-Con Kft. Véső utca 9-11 1133 Budapest Phone +36 1 4124161 Fax +36 1 4124171 tech-con@tech-con.hu	33 拉脱维亚 Techvitas SIA Daugavas iela 38-3 M ū r p, LV-2167 Phone +372 667 5600 Fax +372 667 5601 l_igus.Lettland_G@igus.de	42 荷兰 igus® B.V. Sierrenbergweg 9 3769 BS Soesterberg Phone +31 346 353932 Fax +31 346 353849 info@igus.nl
9 保加利亚 igus® EOOD 2, Lui Ayer str., fl.4, off. 4 1404 Sofia, Bulgaria Phone +359 2 950 8409 Fax +359 2 850 8409 info@igus.bg	18 厄瓜多尔 Ecuainsetec Yugoestlavía N34-110 y Azuay Quito Phone +593 2 2253757 Fax +593 2 2461833 info@ecuainsetec.com.ec	25 匈牙利 Tech-Con Kft. Véső utca 9-11 1133 Budapest Phone +36 1 4124161 Fax +36 1 4124171 tech-con@tech-con.hu	33 拉脱维亚 Techvitas SIA Daugavas iela 38-3 M ū r p, LV-2167 Phone +372 667 5600 Fax +372 667 5601 l_igus.Lettland_G@igus.de	42 荷兰 igus® B.V. Sierrenbergweg 9 3769 BS Soesterberg Phone +31 346 353932 Fax +31 346 353849 info@igus.nl
9 保加利亚 Hennlich OOD, BG 4003 Plovdiv, Bulgaria 147A, Brezovsko шосе Str., Rota center, fl. 3 Phone +359 32 511 326 Fax +359 32 621 929 office@hennlich.bg	19 埃及 IEE International Company for Electrical Engineering 2nd floor, 25 Orabi St Down Town, Cairo Phone +202 25767370 Fax +202 25767375 sales@iee-egypt.com	27 印尼 PT igus® Indonesia Headquarter Indonesia Taman Tekno BSD Sektor XI, Blok L1 No. 15 Tangerang Selatan 15314 Phone +62 21 7538 1933 Fax +62 21 7538 1932 info@igus.co.id	33 拉脱维亚 Techvitas SIA Daugavas iela 38-3 M ū r p, LV-2167 Phone +372 667 5600 Fax +372 667 5601 l_igus.Lettland_G@igus.de	42 荷兰 igus® B.V. Sierrenbergweg 9 3769 BS Soesterberg Phone +31 346 353932 Fax +31 346 353849 info@igus.nl
9 保加利亚 Hennlich OOD, BG 4003 Plovdiv, Bulgaria 147A, Brezovsko шосе Str., Rota center, fl. 3 Phone +359 32 511 326 Fax +359 32 621 929 office@hennlich.bg	19 埃及 IEE International Company for Electrical Engineering 2nd floor, 25 Orabi St Down Town, Cairo Phone +202 25767370 Fax +202 25767375 sales@iee-egypt.com	27 印尼 PT igus® Indonesia Headquarter Indonesia Taman Tekno BSD Sektor XI, Blok L1 No. 15 Tangerang Selatan 15314 Phone +62 21 7538 1933 Fax +62 21 7538 1932 info@igus.co.id	33 拉脱维亚 Techvitas SIA Daugavas iela 38-3 M ū r p, LV-2167 Phone +372 667 5600 Fax +372 667 5601 l_igus.Lettland_G@igus.de	42 荷兰 igus® B.V. Sierrenbergweg 9 3769 BS Soesterberg Phone +31 346 353932 Fax +31 346 353849 info@igus.nl

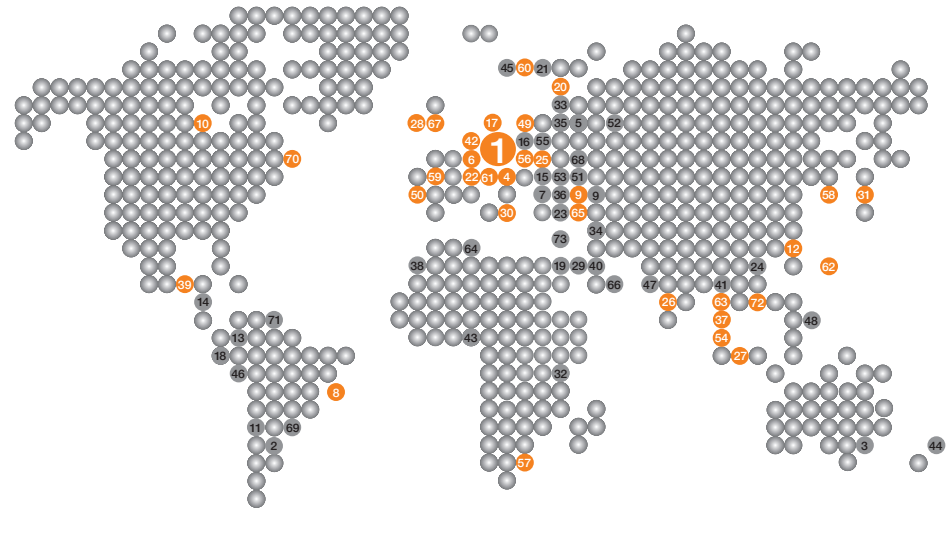

49 波兰 igus® Sp. z o.o. ul. Działkowa 121C 02-234 Warszawa Phone +48 22 8635770 Fax +48 22 8636169 info@igus.pl	55 斯洛伐克 Hennlich s.r.o. Na Bystricku 16 SK-036 01 Martin Phone +421 43 421 2352 Intech@hennlich.sk www.hennlich.sk	60 瑞典 igus® AB Berga Allé 1 254 52 Helsingborg Phone +46 42 329270 Fax +46 42 211585 info@igusab.se	64 突尼斯 BOUDRANT 53, Avenue de Carthage 1000 Tunis - Tunisia Phone +216 71340244 Fax +216 71346910 info@boudrant.com.tn	68 乌克兰 Cominpro GmbH Romena Rollana 12, Office 100 61058 Kharkov Phone +380 57 7174914 Fax +380 57 7174914 cominpro@gmail.com
50 葡萄牙 igus® Lda. R, Eng. Ezequiel Campos, 239 4100-231 Porto Phone +351 22 6109000 Fax +351 22 8328321 info@igus.pt	56 斯洛文尼亚 igus® d.o.o. Tržaška c. 134 1000 Ljubljana Slovenija Mob. +386 (0)30 601 610 info@igus.si	60 瑞典 OEM Automatic AB Box 1011 Dalagatan 4 573 28 Tranås Phone +46 75 242100 Fax +46 75 242159 info@oemautomatic.se	65 土耳其 igus® Turkey Güzeller Org. San. Bölg. Galvano Teknik San. Sit. Cumhuriyet Cad. 2/32 P.K. 41400 Gebze / Kocaeli Phone +90 262 502 14 08 Fax +90 262 502 14 19 info@igus.com.tr	69 乌拉圭 Larrique Rulemanes SA Galicía 1204 Montevideo-Uruguay Phone +598 29021773 Fax +598-29084824 larrique@larrique.com.uy info@igus.com.tr
51 罗马尼亚 Hennlich SRL Str. Patria, Nr17 310106 Arad Phone +40 257 211119 Fax +40 257 211021 igus@hennlich.ro	56 斯洛文尼亚 Hennlich d.o.o. Industrijska tehnika Podnart 33 SI-4244 Podnart Phone +386 4 53206-10 Fax +386 4 53206-20 info@hennlich.si	60 瑞典 Colly Components AB Raseborgsgatan 9 P.O. Box 76 164 94 Kista Phone +46 8 7030100 Fax +46 8 7039841 info@me.colly.se	65 土耳其 HIDREL Hidrolik Elemanlar Sanayi ve Ticaret A.Ş. Perçemli Sk. No. 7 Tünel Merki 34420 Karaköy / Istanbul Phone +90 212 2494881 Fax +90 212 2920850 info@hidrel.com.tr	70 美国 igus® inc. 257 Ferris Avenue P.O. Box 14349 East Providence RI 02914 Phone +1 401 4382200 Fax +1 401 4387270 webmaster@igus.com
52 俄罗斯 OOO Hennlich Room 14 Naberezhnaya reki Lazuri, 15A 170028 Tver Russian Federation Phone +7 4822 787 180 Fax +7 4822 787 180, add.380 hennlich@hennlich.ru	57 南非 igus® Pty. Ltd. Unit 29 Midline Business Park Chr Le Roux & Richards Drive Midrand 1692 Phone +27 11312-1848 Fax +27 11312-1594 sales.sa@igus.de	61 瑞士 igus® Schweiz GmbH Winkelstr. 5 4622 Egerkingen Phone +41 62 388 97 97 Fax +41 62 388 97 99 info@igus.ch	66 阿联酋+阿曼 Unigroup FZE Sharjah Airport Free Zone P.O. Box 120300 Sharjah - U.A.E. Phone +971 6 5578386 Fax +971 6 5578387 automation@unigroup.ae	71 委内瑞拉 Neumatica Rotonda C.A. Prolong Av. Michelena C.C. Atlas Locales B-10 y B-11 Valencia, Edo., Carabobo Phone +58 241 832.64.64 +58 241 832.32.50 +58 241 838.88.19 +58 241 832.62.83 ventas@neumaticar.com
53 塞尔维亚+黑山 Hennlich doo Beograd Radomira Markovića 1/3 11222 Beograd / Srbija Phone +381 11 63 098 17 Fax +381 11 63 098 20 office@hennlich.rs	58 韩国 igus® Korea Co. Ltd. 613-14 Namchongdong, Namdonggu Incheon City, 405-846 Phone +82 32 82129-11 Fax +82 32 82129-13 info@igus.kr	62 台湾 igus® Taiwan Company Ltd. 5F, No. 35, 24th Road Taichung Industrial Park Taichung 40850 Phone +886 4 2358-1000 Fax +886 4 2358-1100 info@igus.com.tw	67 英国 igus® Caswell Rd Northampton NN4 7PW Phone +44 1604 677240 sales@igus.co.uk	72 越南 igus® Vietnam Company Ltd 1/7 Huynh Lan Khanh Street, Ward 2 District Tan Binh, HCM City, Vietnam Phone +84 28 3636 4189 info@igus.vn
54 新加坡 - 东盟 igus® Singapore Pte Ltd 84 Genting Lane #06-03 Axxel Innovation Centre Singapore 349564 Phone +65 6487 1411 info@igus.com.sg	58 韩国 igus® Korea Co. Ltd. 613-14 Namchongdong, Namdonggu Incheon City, 405-846 Phone +82 32 82129-11 Fax +82 32 82129-13 info@igus.kr	63 泰国 igus® Thailand Co. Ltd 1540 Soi Bangkok-Nonthaburi 30, Bangkok-Nonthaburi Rd., Bangsue, Bangsue Bangkok 10800 Phone +66 (0)2 587 4899 Fax +66 (0)2 587 4898 info@igus.co.th	68 乌克兰 Hennlich Ukraine LLC (HQ) Kramatorska Street 15 84100 Slovnyansky City, Donetsky Region Phone +38 06262 33540 hennlich@hennlich.com.ua	73 塞浦路斯 G.C.V. Spare Parts & Services Ltd (HQ) Industrial Area Anatoliko 8068 Pafos Phone +357 26 812444 +357 26 812447 igus@gcv-parts.com
48 菲律宾 Silicon Exponents Corp. Unit 1-B, 841 LNM Bldg., Dr. A. Santos Avenue Brgy.BF Homes Sucat Parañaque City 1700 Philippines Phone +63 2 8250 126/135 Fax +63 2 8250 141 ryemrigor@sieluph.ph	59 西班牙 igus® S.L.U. Ctra. Libatona, 6 Poligono Nri del Sucre 08840 Viladecans – BCN Phone +34 936 473950 Fax +34 936 473951 igus.es@igus.es	68 乌克兰 Hennlich Ukraine LLC (HQ) Kramatorska Street 15 84100 Slovnyansky City, Donetsky Region Phone +38 06262 33540 hennlich@hennlich.com.ua	73 塞浦路斯 G.C.V. Spare Parts & Services Ltd (HQ) Industrial Area Anatoliko 8068 Pafos Phone +357 26 812444 +357 26 812447 igus@gcv-parts.com	

igus.com.cn/20h

订购和发货时间周一到周六，8:00-20:00。无最小起订量，无额外费用。80000种产品常备库存，快速发货。 Ordering and deliveries monday - Saturday from 8:00 am to 20:00 pm. No minimum order quantities, no surcharges. 80,000 products available ex-stock. Quick delivery.
www.igus.com.cn www.igus.eu

igus.com.cn/24

在线商铺 - 24 小时! Online shopping -24h!
更多在线样本和宣传册 - www.igus.com.cn/downloads
More catalogs and brochures online - www.igus.eu/downloads

/9001:2015 /16949:2016

易格斯拖链、轴承、电缆及装配符合ISO 9001:2015
及IATF 16949:2016 标准。

/newsletter

免费订阅! 了解更多易格斯 motion plastics® 的信息，更多行业应用案例，在线注册：
www.igus.com.cn/newsletter

igus®

易格斯(上海)拖链系统有限公司
上海市奉贤区环城北路50号
邮编: 201401
电话: 021- 8036 6999
传真: 021- 8036 6116
免费服务热线: 400 720 3100
E-mail: cnmaster@igus.net
<https://www.igus.com.cn>

MAT0071419.14 截至 12/2013
易格斯保留最终解释权
*更新至 01/04/2013

handling

material